



Enabling Industrial IoT



ZETA-xxP Series

LTE Cat 1 / LTE Cat 4 / LTE Cat M1 /
LTE Cat NB1 / UMTS / GSM
Ultra Low Power Modem

Hardware Manual

Rev 2.3



Table of Contents

	Page		Page
Introduction	3	Power	44
About Siretta	4	RJ12 Power Connector	44
General Description	5	Power Supply Requirements	46
Specifications	6	Switching the Modem ON/OFF	47
AT Commands	16	Embedded Software Support	53
ZETA-xxP Interface	17	Telit AppZone	53
System Diagram	19	Telit AppZone - Lightweight, fast and efficient	54
System Overview	21	Installation	55
Modes of Operation	22	Considerations for Installations Incorporating the ZETA-xxP	55
Ordering Information	23	Power Supply Installations	56
Dimensions	24	Securing the Modem	56
ZETA-xxP Series Images	27	Regulatory Approvals	57
LED Indicators	28	Safety and Product Care	60
Interfaces	31	General Precautions	60
RS232 Serial Port Interface	31	SIM Card Precautions	60
USB Serial Port Interface	32	Antenna Precautions	61
USB Interface Drivers	33	Exposure to RF Energy	61
GPIO 10-Way Connector	34	Safety Recommendations	63
SIM Socket	35	Conformity Assessment	64
SIM Requirements	35	Disclaimer	65
Digital Functions	36	Definitions	66
Digital Output	36		
Digital Input	37		
Configuration Switch (Emergency Boot)	38		
Antenna Connectors	39		
Cellular Antenna Connector	40		
GNSS Antenna Connector	41		
GNSS	42		
ZETA-GEP Modem	42		



Introduction

This document is intended to provide guidance when adding a modem from the ZETA-xxP series to your system.

The ZETA-xxP series of LTE Cat 1/LTE Cat 4/LTE Cat M1/LTE Cat NB1/UMTS/GSM Ultra Low Power modems are an advanced range of high performance modems developed for easy integration into existing systems and for embedded application development.

The ZETA-xxP modem range is based on the Telit xE910 GPRS/UMTS/LTE module series and is designed to be ultra low power for use in power sensitive applications. The modem manages the module power up sequence and can be programmed to perform additional custom tasks. In addition to offering 2G/GSM fallback the modem also provides access to the new LTE Cat M1 and LTE Cat NB1 networks for full future compatibility.

The modem family is also available with current LTE Cat 1 and LTE Cat 4 variants for high speed applications.

This document discusses the modems states and modes of operation in addition to the electrical characteristics of the modems interfaces.



About Siretta

Siretta is a wireless communications company located in Reading, United Kingdom manufacturing & supplying industrial IoT products since the early 2000s.

Siretta's product portfolio is made up of:

- » Antennas, plus their associated Cable Assemblies & Adapters,
- » Cellular Network Analysers
- » Industrial Modems
- » Industrial Routers
- » Associated Cloud Management

Siretta supplies products directly and via a worldwide network of distributors, into numerous markets and applications across the globe.

Siretta's distribution partners range from industrial IoT specialists through to global catalogue organisations.

Whether "off the shelf" or custom solutions are required, Siretta has a wide portfolio of products to fit many types of application.

Siretta's extensive knowledge and experience in the wireless market allows support of a wide range of customer applications, focusing on frequencies between 150 MHz to 6 GHz. These encompass modems, routers and antennas for:

- » Cellular technologies: GSM/GPRS/3G/UMTS/4G/LTE & 5G NR, plus LTE CAT 1, LTE CAT M & LTE CAT NB-IoT
- » Global positioning: GPS/GNSS
- » WLAN/Wi-Fi

Whilst providing the above products for the industrial cellular market, Siretta also has a number of antennas to cover applications for:

- » Bluetooth, Zigbee, ISM band, LoRa and Sigfox

With a heavy emphasis on design, Siretta has a team of dedicated Engineers and Product Managers, who specialise in wireless applications.

Siretta continually makes significant investment in R&D endeavouring to provide customers with market leading, future-proofed, wireless solutions. Siretta works closely with many technology partners to stay at the forefront of industrial IOT.



General Description

The ZETA-xxP range of LTE Cat 1/LTE Cat 4/LTE Cat M1/LTE Cat NB1/UMTS/GSM Ultra Low Power modems are amongst the most versatile modem series available today. The ZETA-xxP series offers a range of interface options including USB and RS232 serial port communication, for connection to existing legacy equipment and high speed USB interfaces.

The ZETA-xxP has been designed from the ground up to be very power efficient and incorporates some unique features to allow it to run in an ultra low power state when utilizing the standard AT+CFUN=5 low power mode.

The Siretta ZETA-xxP contains a powerful C development environment which reduces redundancy and optimizes the architecture of your solution and lowers system component costs. In a typical integration project, IoT device developers employ a microcontroller to manage the modem functionality and other device peripherals. The Siretta ZETA-xxP integrates Telit IoT AppZone which eliminates the requirement for an external controller, reducing cost and complexity, embedding application code right in the module.

The Siretta ZETA-xxP Includes a comprehensive set of high-level enabling functions allowing you to focus on the market-differentiating value-added features of your application software. Reduces time to market and project costs; and when you complete your development, reuse it across different products and technologies to expand your markets and opportunities.

Create a proof of concept in record time and with minimal investment. Leverage robust building blocks to shorten your development cycles through to mass deployment.



Specifications

Mechanical

Table 1. ZETA-xxP series mechanical specifications

Parameter	Description
Dimensions	93 x 67 x 28 mm
Weight	
ZETA-NLP/NSP	92.5 g
ZETA-NEP	92.8 g
ZETA-GEP	97.2 g
Case	Black ABS plastic
Operating Temperature	-40 to +85 °C
Antenna Connector(s)	SMA Female
USB Connector	Mini USB type B
RS232 Connector	Female 9-pin D-type with locknuts
Power Connector	RJ12
IO Connector (Enhanced order option)	10 way (2x5), 2 mm pitch

Interface

Table 2. ZETA-xxP series interfaces

Parameter	Description
Operating Voltage	7 to 42 V
Antenna Impedance	50 Ohm
USB Speed	USB 2.0 (High speed 480 Mbits/sec and full speed 12 Mbits/sec)
RS232 Signals	TX, RX, DCD, DTR, DSR, CTS, RTS and RI
RS232 Baud Rates	2400, 4800, 9600, 19200, 38400, 57600, 115200, 230400
RS232 Connector	Female 9-pin D-type with locknuts
Power Connector	RJ12



Power Consumption

All power consumption figures are when powered from the recommended 12 V power supply, modem at default settings, and using the RS232 interface unless otherwise specified. All values are calculated rather than measured values.

Table 3. Power consumption of ZETA LTE Ultra Low Power versions

Mode (ZETA LTE Ultra Low Power Versions)	Typical Consumption
Switched off (using PWROFF_IN on the RJ12 connector)	0.9 mA
On, registered, no call in progress, AT+CFUN=1	11.1 mA
On, not registered, flight mode, AT+CFUN=4	10.7 mA
On, registered on LTE, no call in progress, 2.56 sec DRx cycle, AT+CFUN=5	1.5 mA
On, registered on LTE, no call in progress, 1.28 sec DRx cycle, AT+CFUN=5	1.6 mA
On, registered on UMTS, no call in progress, DRx8, AT+CFUN=5	1.4 mA
On, registered on UMTS, no call in progress, DRx7, AT+CFUN=5	1.5 mA
On, registered on GSM , no call in progress, DRx5, AT+CFUN=5	1.5 mA
On, registered on GSM , no call in progress, DRx2, AT+CFUN=5	1.7 mA
Operating on LTE, maximum transmit power	318 mA
Operating on LTE, minimum transmit power	112 mA
Operating on UMTS, maximum transmit power	231 mA
Operating on UMTS, minimum transmit power	84.6 mA
Operating on GSM, 900 MHz, maximum power	185 mA
Operating on GSM, 1800 MHz, minimum power	126 mA
GNSS active, Cellular connection idle	20.1 mA



Table 4. Power consumption of ZETA LTE Low Power versions

Mode (ZETA LTE Low Power Versions)	Typical Consumption
Switched off (using PWROFF_IN on the RJ12 connector)	0.9 mA
On, registered, no call in progress, AT+CFUN=1	11.6 mA
On, not registered, flight mode, AT+CFUN=4	11.2 mA
On, registered on LTE, no call in progress, 2.56 sec DRx cycle, AT+CFUN=5	7.1 mA
On, registered on LTE, no call in progress, 1.28 sec DRx cycle, AT+CFUN=5	7.2 mA
On, registered on UMTS, no call in progress, DRx8, AT+CFUN=5	7.0 mA
On, registered on UMTS, no call in progress, DRx7, AT+CFUN=5	7.1 mA
On, registered on GSM , no call in progress, DRx5, AT+CFUN=5	7.1 mA
On, registered on GSM , no call in progress, DRx2, AT+CFUN=5	7.3 mA
Operating on LTE, maximum transmit power	319 mA
Operating on LTE, minimum transmit power	113 mA
Operating on UMTS, maximum transmit power	231 mA
Operating on UMTS, minimum transmit power	85.1 mA
Operating on GSM, 900 MHz, maximum power	185 mA
Operating on GSM, 1800 MHz, minimum power	127 mA
GNSS active, Cellular connection idle	20.5 mA



Table 5. Power consumption of ZETA LTEM Ultra Low Power versions

Mode (ZETA LTEM Ultra Low Power Versions)	Typical Consumption
Switched off (using PWROFF_IN on the RJ12 connector)	0.9 mA
On, registered, no call in progress, AT+CFUN=1	10.1 mA
On, not registered, flight mode, AT+CFUN=4	9.7 mA
On, registered on LTE, no call in progress, 2.56 sec DRx cycle, AT+CFUN=5	1.0 mA
On, registered on LTE, no call in progress, 1.28 sec DRx cycle, AT+CFUN=5	1.1 mA
On, registered on LTE, no call in progress, 0.64 sec DRx cycle, AT+CFUN=5	1.6 mA
Operating on LTE Cat M1, maximum transmit power	73.8 mA
Operating on LTE Cat M1, minimum transmit power	46.3 mA
Operating on LTE Cat NB1, maximum transmit power	23.7 mA
Operating on LTE Cat NB1, minimum transmit power	16.4 mA
Operating on GSM, 900 MHz GPRS, maximum power	91.8 mA
Operating on GSM, 900 MHz GPRS, minimum power	46.3 mA
Operating on GSM, 900 MHz EDGE, maximum power	188.3 mA
Operating on GSM, 900 MHz EDGE, minimum power	52.8 mA
GNSS active, Cellular connection idle	16.4 mA



Table 6. Power consumption of ZETA LTEM Low Power versions

Mode (ZETA LTEM Low Power Versions)	Typical Consumption
Switched off (using PWROFF_IN on the RJ12 connector)	0.9 mA
On, registered, no call in progress, AT+CFUN=1	10.6 mA
On, not registered, flight mode, AT+CFUN=4	10.2 mA
On, registered on LTE, no call in progress, 2.56 sec DRx cycle, AT+CFUN=5	6.7 mA
On, registered on LTE, no call in progress, 1.28 sec DRx cycle, AT+CFUN=5	6.8 mA
On, registered on LTE, no call in progress, 0.64 sec DRx cycle, AT+CFUN=5	7.2 mA
Operating on LTE Cat M1, maximum transmit power	74.3 mA
Operating on LTE Cat M1, minimum transmit power	46.8 mA
Operating on LTE Cat NB1, maximum transmit power	24.2 mA
Operating on LTE Cat NB1, minimum transmit power	16.9 mA
Operating on GSM, 900 MHz GPRS, maximum power	92.3 mA
Operating on GSM, 900 MHz GPRS, minimum power	46.8 mA
Operating on GSM, 900 MHz EDGE, maximum power	188.8 mA
Operating on GSM, 900 MHz EDGE, minimum power	53.3 mA
GNSS active, Cellular connection idle	16.9 mA

NOTES:

- » An additional 0.5 mA of power is required for ZETA fitted with the IO connector (Enhanced order option) regardless of the power state on the ZETA. This does not include any current provided by any of the pins on the IO port and is with the RS232 debug connection inactive.
- » Power consumption does depend on network conditions that cannot be controlled by the ZETA or application in which it is used. It is possible to see both higher and lower power consumption values than those presented here.
- » 'Operating' is defined as connected to the network and sending data at the maximum data rate through the USB interface.
- » The transmit power level will normally be set automatically by the modem depending on network conditions. Maximum power will occur at low received signal strengths and minimum power at high received signal strengths.
- » GNSS power consumption does not include any power provided to power an active GNSS antenna



Ultra Low Power Option

The ultra low power option allows a ZETA with this option and using the RS232 interface to go into an ultra low power state where it will remain connected to the cellular network and automatically wake from this state if there is incoming cellular network activity detected. No network traffic will be lost.

This mode of operation is executed using the AT Command AT+CFUN=5.

ZETA without the ultra low power option can also use AT+CFUN=5 to enter a low power operation, but they do not contain the extra functionality to reduce the power consumption to the levels that the ultra low power option offers.

Network Support

Table 7. Network support for ZETA-xxP series

ZETA Version	GSM	UMTS	LTE Cat 1	LTE Cat 4	LTE Cat M1	LTE Cat NB1
LTE1 (EU)	✓	✓	✓			
LTE4 (EU)	✓	✓	✓	✓		
LTE1 (USA)		✓	✓			
LTE4 (USA)		✓	✓	✓		
LTE1 (AP)		✓	✓			
LTE4 (AP)		✓	✓	✓		
LTEM (GL)	✓				✓	✓



Frequency Band Support

Table 8. GSM frequency band support

GSM Band	Frequency	Common name	LTE (EU)	LTE (USA)	LTE (AP)	LTEM (GL)
B2	1900 MHz	PCS				✓
B3	1800 MHz	DCS	✓			✓
B5	850 MHz	Cellular				✓
B8	900 MHz	Extended GSM	✓			✓

Table 9. UMTS frequency band support

UMTS Band	Frequency	Common name	LTE (EU)	LTE (USA)	LTE (AP)	LTEM (GL)
B1	2100 MHz	IMT	✓		✓	
B2	1900 MHz	PCS		✓		
B3	1800 MHz	DCS	✓			
B4	1700 MHz	AWS-1		✓		
B5	850 MHz	Cellular		✓	✓	
B6	800 MHz	UMTS 800			✓	
B8	900 MHz	Extended GSM	✓		✓	
B19	850 MHz	Upper 800 (Japan)			✓	



Table 10. LTE frequency band support

LTE Band	Frequency	Common name	LTE (EU)	LTE (USA)	LTE (AP)	LTEM (GL)
B1	2100 MHz	IMT	✓		✓	✓
B2	1900 MHz	PCS		✓		✓
B3	1800 MHz	DCS	✓		✓	✓
B4	1700 MHz	AWS-1		✓		✓
B5	850 MHz	Cellular		✓	✓	✓
B7	2600 MHz	IMT-E	✓			
B8	900 MHz	Extended GSM	✓		✓	✓
B9*	1800 MHz	DCS			✓	
B12	700 MHz	Lower SMH		✓		✓
B13	700 MHz	Upper SMH		✓		✓
B14	700 MHz	Upper SMH		✓		
B18	850 MHz	Lower 800 (Japan)			✓	✓
B19	850 MHz	Upper 800 (Japan)			✓	✓
B20	800 MHz	Digital Dividend	✓			✓
B26	850 MHz	Extended Cellular			✓	✓
B28	700 MHz	APT			✓	✓
B28A**	700 MHz	APT	✓			
B66	1700 MHz	Extended AWS		✓		
B71	600 MHz	Digital Dividend (US)		✓		

*B9 was intended for use in Japan, but not deployed

**B28A is a subset of B28 using the lower duplexer frequencies
(Tx : 703-733 MHz / Rx : 758-788 MHz)



Data Transfer Rates

Table 11. Data transfer rates

Technology	Upload	Download
2G / GSM-EDGE*	236 kbps	296 kbps
3G / UMTS	5.76 Mbps (ZETA LTE1)	7.2 Mbps (ZETA LTE1)
3G / UMTS**	11.5 Mbps (ZETA LTE4)	42 Mbps (ZETA LTE4)
LTE Cat 1	5 Mbps	10 Mbps
LTE Cat 4	50 Mbps	150 Mbps
LTE Cat M1	375 kbps	300 kbps
LTE Cat NB1	62.5 kbps	21 kbps

*The ZETA supports EDGE. This is an enhanced (but backwardly compatible) version of GPRS, sometimes referred to as 2.75G. Not all networks can be assumed to support this, in which case the GPRS data rates will apply.

**DC-HSPA+ supported

NOTE: These data transfer rates are the data rates supported by the ZETA. Good network reception and a connected cell tower supporting these data rates is also required to get these transfer rates. To get the highest connection speeds, the USB interface of the ZETA must be used.

IO Connector (Enhanced order option)

The optional IP connector on the Enhanced ZETA supports the following functions:

- » 1x 3-wire RS232 debug port connected directly to the cellular module
- » 1x output voltage (to be used to power external interfaces and as a reference for the GPIO)
- » 1x 12-bit ADC (42 V tolerant)
- » 3x General purpose inputs (42 V tolerant)
- » 2x General purpose open collector outputs (Capable of sinking 1 A @ 42 V)



Diversity (Order option)

The ZETA may be ordered with a second antenna connection to improve radio sensitivity. The function is called Antenna Diversity. Diversity improves the input sensitivity by up to 2 dB, which could aid operation in low signal strength areas. Channel aggregation is not supported by this option.

Diversity is mutually exclusive with the GNSS option.

GNSS (Order option)

GNSS is mutually exclusive with the diversity option. The characteristics of the GNSS receiver are:

Table 12. GNSS receiver specifications

Parameters	Typical Measurement	Notes
Sensitivity		
Standalone or MS Based Tracking Sensitivity	-160.0 dBm	
Acquisition	-147.0 dBm	
Cold Start Sensitivity	-145.0 dBm	
TTFF		
Hot	1.1 s	GPS + Glonass Stimulator Test
Warm	22.1 s	GPS + Glonass Stimulator Test
Cold	29.94 s	GPS + Glonass Stimulator Test
Accuracy	0.8 m	GPS + Glonass Stimulator Test
Min Navigation Update Rate	1 Hz	
Dynamics	2 g	
Operation Limits	515 m/sec	
A-GPS	Supported	

These values are for a typical ZETA being used in typical environment and conditions. Device to device deviation is within 2 dB of the quoted sensitivity.



AT Commands

The ZETA-xxP range of wireless modems has a cellular engine at its heart which can be controlled via the serial interface using standard AT commands.

The AT command is an ATTENTION command and is used as a prefix to other parameters in a formatted string. The AT command combined with other parameters can be sent to the modem with your preferred terminal emulator package (TeraTerm/HyperTerminal) and typed in manually as a command line instruction.

The wireless module is compliant with the following AT command formats:

- 1) Hayes standard AT command set, in order to maintain the compatibility with existing SW programs.
- 2) 3GPP 27.007 AT command set for User Equipment (UE).
- 3) 3GPP 27.005 Data Circuit terminating Equipment (DTE - DCE) interface for Short Message Service (SMS) and Cell Broadcast Service (CBS).
- 4) Proprietary command set, the module family also supports a proprietary set of AT commands for special purposes outside of the standard AT specification.

To obtain the latest AT command reference guide with a full list of supported AT commands, please contact your Siretta representative or alternatively visit:

This following document refers to useful AT commands throughout and offers descriptions of how to use the AT commands with the ZETA-xxP wireless modems.

*For all LTE modems refer to the latest LTE AT Command Manual.



ZETA-xxP Interface

Standard Hardware Interfaces

The ZETA-NLP and ZETA-NSP modem series come complete with the following interfaces:

- » 1 x RS232 serial port interface for direct serial connection to module (9 wire interface)
- » 1 x RJ12 power connection with 2 power lines (7- 42 V) and 4 input interfaces
- » 1 x SMA female cellular antenna connector
- » 1 x SIM card reader (push-push)
- » 3 x external LED status indicators (Red, Green, Blue)
- » 1 x FS USB port

The ZETA-NEP modem series comes complete with the following interfaces:

- » 1 x RS232 serial port interface for direct serial connection to module (9 wire interface)
- » 1 x RJ12 power connection with 2 power lines (7- 42 V) and 4 input interfaces
- » 1 x SMA female cellular antenna connector
- » 1 x SIM card reader (push-push)
- » 3 x external LED status indicators (Red, Green, Blue)
- » 1 x FS USB port
- » 10-Way connector
 - 1 x wired (10-way) RS232 debug port for direct serial connection to module (3 wire interface)
 - 1 x wired (10-way) 3.3V power supply output interface
 - 1 x wired (10-way) 12-bit ADC interface (42 V tolerant)
 - 3 x wired (10-way) general purpose input interfaces (0-42 V)
 - 2 x wired (10-way) general purpose output interface (VCC @ 1 A)



The ZETA-GEP modem series comes complete with the following interfaces:

- » 1 x RS232 serial port interface for direct serial connection to module
- » 1 x RJ12 power connection with 2 power lines (7- 42 V) and 4 input interfaces
- » 1 x SMA female cellular antenna connector
- » 1 x SMA female GNSS antenna connector
- » 1 x SIM card reader (push-push)
- » 3 x external LED status indicators (Red, Green, Blue)
- » 1 x FS USB port
- » 10-Way connector
 - 1 x wired (10-way) RS232 debug port for direct serial connection to module (3 wire interface)
 - 1 x wired (10-way) 3.3V power supply output interface
 - 1 x wired (10-way) 12-bit ADC interface (42 V tolerant)
 - 3 x wired (10-way) general purpose input interfaces (0-42 V)
 - 2 x wired (10-way) general purpose output interface (VCC @ 1 A)

Optional Modem Features*

Optional Technologies

The ZETA-xxP series modems have the following optional technologies available:

- » GPRS (2G)
- » UMTS (3G)
- » LTE Cat 1 (4G)
- » LTE Cat 4 (4G)
- » LTE Cat M1
- » LTE Cat NB1

Optional Coverage

The ZETA-xxP series modems have the following coverage options available:

- » (EU) European Union
- » (USA) North America
- » (AP) Asia Pacific
- » (GL) Global

*To add optional features on your modem, see ordering Information on page 23.

System Diagram

The ZETA-xxP series is a versatile range of modems offering multiple communication channels and interfaces to connect into other systems. The system diagram below gives a visual representation of the ZETA-xxP interfaces available to the user and shows the various subsections which make up the complete ZETA-xxP modem.

Figure 1. ZETA-NLP / ZETA-NSP Block Diagram

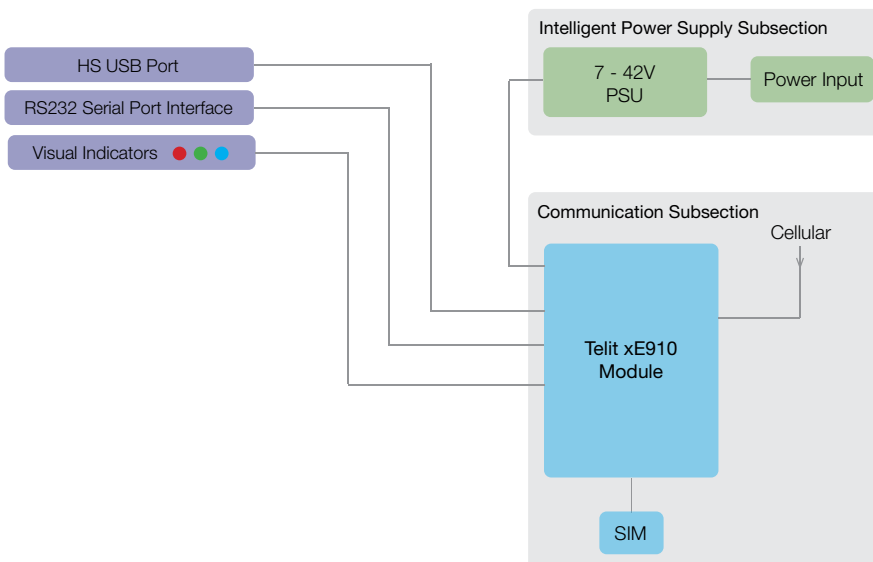

Figure 2. ZETA-NEP Block Diagram*

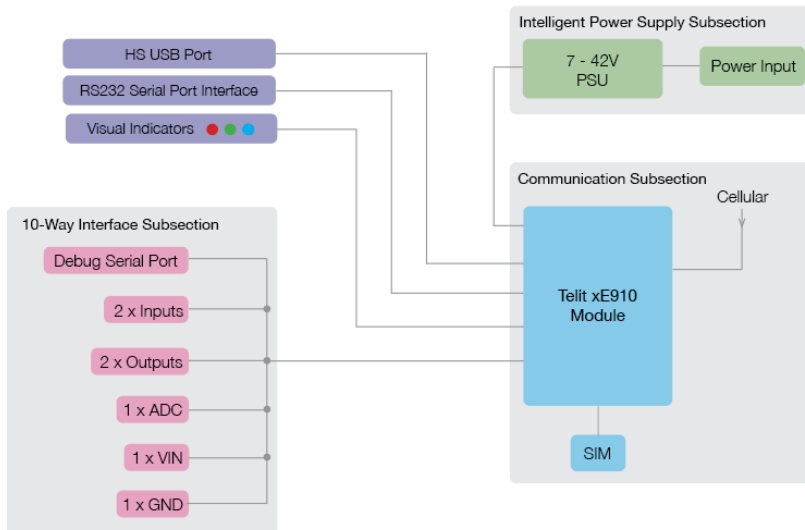
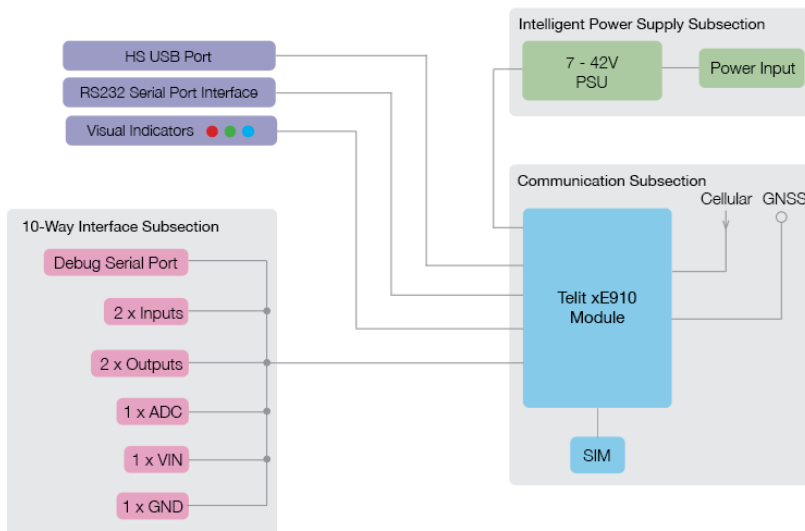

Figure 3. ZETA-GEP Block Diagram*



*Important information regarding pin 7 of the 10-Way connector:
 Devices with batch code 44055 or greater output VIN on pin 7
 Devices with batch code less than 44055 output 3.3 V on pin 7



System Overview

This ZETA-xxP can be used in a number of applications, some examples are shown below:

- » Low power cellular communication interface
- » Upgrade your estate with a low power solution which continues to operate on the existing cellular network
- » Future proof your applications today by installing a 4G/LTE compatible solution which operates with 2G/GSM fall back
- » Standard cellular modem attached to existing equipment (Windows / WinCE / Linux)*

*Appropriate Telit USB driver needs to be installed (if using USB port with USB cable). Device drivers can be downloaded from: <https://www.siretta.com/usb-drivers>

Appropriate USB driver needs to be installed (if using USB to RS232 cable). Device drivers can be downloaded from: <https://www.siretta.com/serialdrivers>

Typically connected devices are:

- » Windows / WinCE / Linux platforms for use as a dial-up modem
- » Embedded (connected directly to remote equipment without a PC attached)

Operating System Connected Modem

- » Internet enable a remote device with RS232 and/or USB connectivity over 2G/ GPRS, 3G/UMTS, LTE Cat M1, LTE Cat NB1, LTE Cat 1, LTE Cat 4. Internet connectivity can be retrofitted to end equipment without changing the software or configuration of the remote device.
- » Used in countries or places where broadband and WiFi is a less common method to connect to the internet or where services are unavailable. The ZETA-xxP modem can overcome this restriction by providing a mobile internet solution over the cellular network.

Examples:

- » Vending machine where the head office would poll for drinks remaining/money taken etc. This would be an on-demand pull to obtain results in real time.
- » Monitoring AMR/temperature/equipment in a home, i.e. Interrogate lights etc.
- » Remote entry system, i.e. Send a message to the modem to open a gate/door to allow access.
- » Streaming live data from remote system to a central location
- » Remote printing applications (remotely print over the cellular network)
- » Polling remote devices for information to prevent an engineer callout

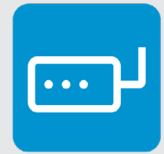

Modes of Operation

USB Interface

This is a USB standard Communication Device Class (CDC) device. A device driver is available for Windows OS. Linux uses standard CDC ACM drivers.

Appropriate Telit USB driver needs to be installed (if using USB port with USB cable).
Device drivers can be downloaded from: <https://www.siretta.com/usb-drivers>



Ordering Information

ZETA - XXX - XXXX (XX)

Modem Identifier

ZETA = Siretta Low Power Modem

Module Type

N = Without GNSS
 G = With GNSS (GPS, Glonass, Beidou, Galileo, QZSS)
 LP = Ultra Low Power
 SP = Low Power
 EP = Enhanced Low Power
 ED = Enhanced Low Power with Diversity
 SD = Low Power with Diversity

Product Module Version

LTE1 = LTE Cat 1 Technology
 LTE4 = LTE Cat 4 Technology
 LTEM = LTE Cat M1 / LTE Cat NB1 Technology

Coverage Options

(EU) = European Coverage of 2G / GSM, 3G / UMTS and 4G / LTE
 (USA) = North America Coverage of 3G / UMTS and 4G / LTE
 (GL) = Global Coverage of 2G / GSM and 4G / LTE
 (AP) = Asia Pacific Coverage of 3G / UMTS and 4G / LTE

Part Numbering Examples

- » ZETA-NLP-LTEM (GL) = Ultra Low Power Global Coverage LTE Cat M1 / LTE Cat NB1 Modem
- » ZETA-NSP-LTE1 (EU) = Low Power European Coverage LTE Cat 1 Modem
- » ZETA-GEP-LTE4 (EU) = Low Power European Coverage LTE Cat 4 Modem with GPIO and GNSS

Accessories

- » 60942 - 12V, 1A mains power supply adapter
- » 61064 - RJ12 to open end cable, 1m, to connect to DC power

Dimensions

All dimensions are shown in mm.

Figure 4. ZETA-NLP and ZETA-NSP modem variants
Side view showing LED indicators and SIM card holder slot

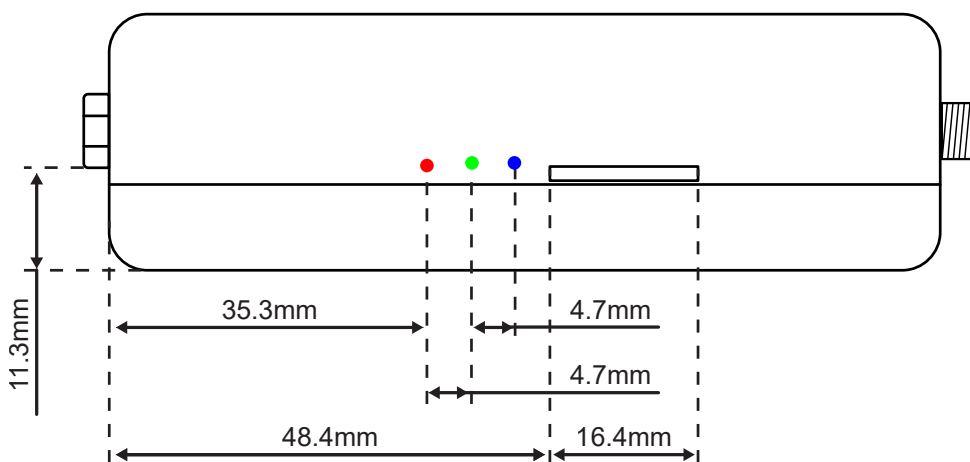

Figure 5. ZETA-NEP and ZETA-GEP modem variants
Side view showing 10-Way IO Header, LED indicators and SIM card holder slot

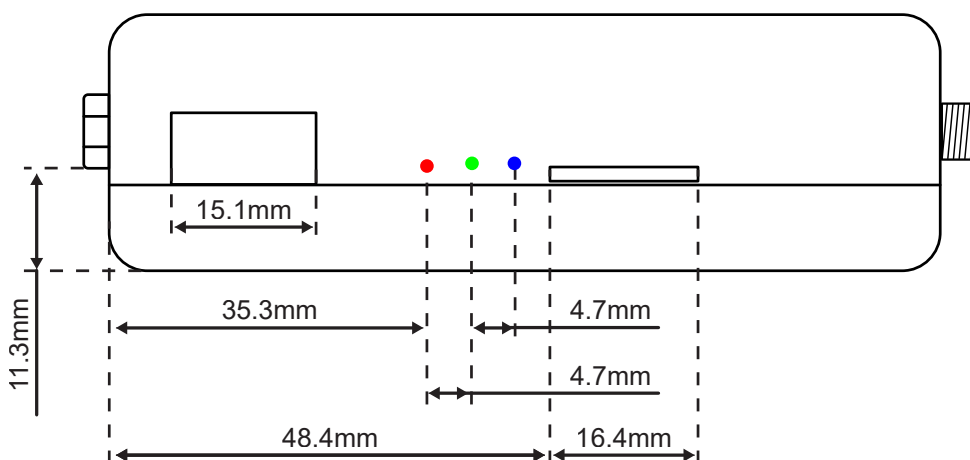

Figure 6. ZETA-xxP modem variants
End view showing RS232 and USB connectors

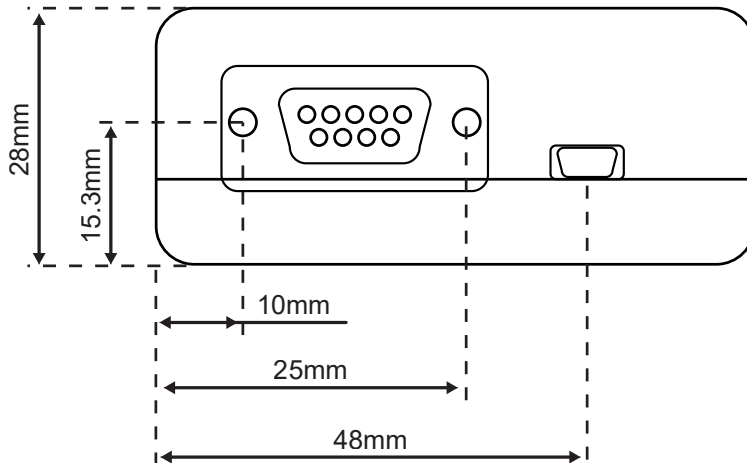

Figure 7. ZETA-NxP modem variant
End view showing antenna and power connectors

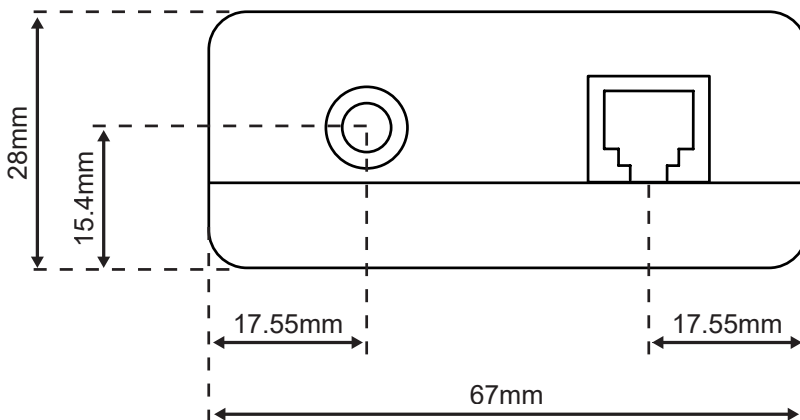

Figure 8. ZETA-GxP modem variant
End view showing antenna and power connectors

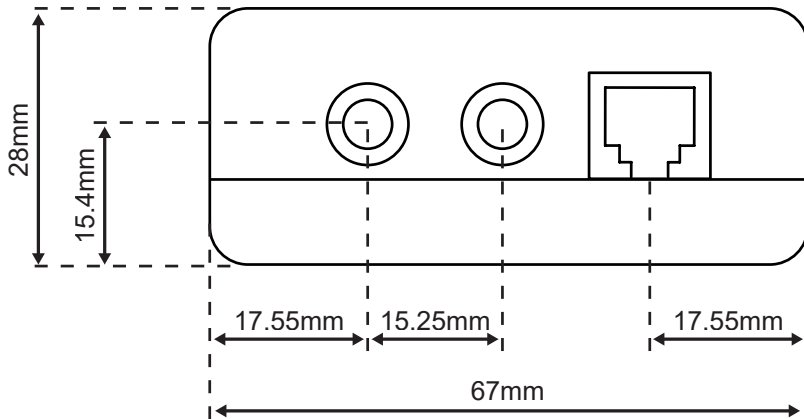
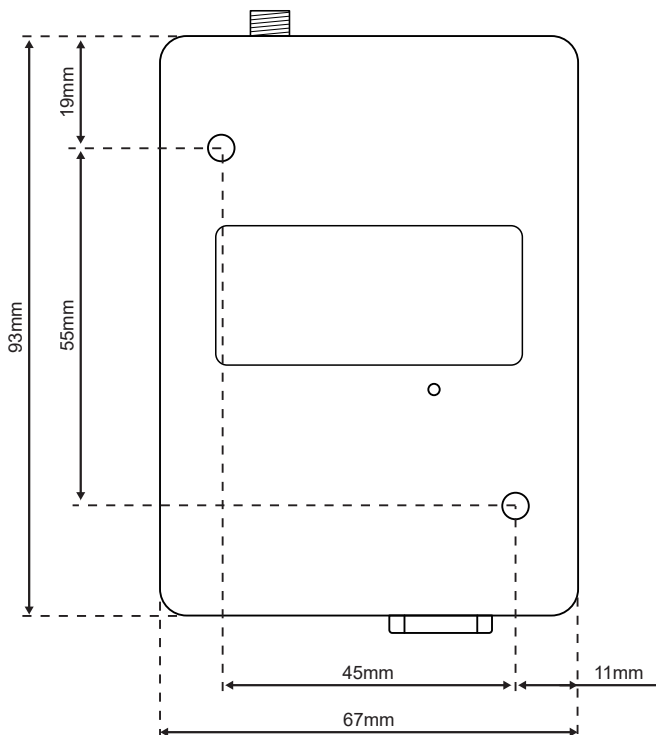

Figure 9. ZETA-GxP modem variant
End view showing antenna and power connectors



ZETA-xxP Series Images

Figure 10. ZETA-NLP, ZETA-NSP and ZETA-NEP



Figure 11. ZETA-GEP



Figure 12. 3D view of the ZETA-NLP and ZETA-NSP



Figure 13. 3D view of the ZETA-NEP and ZETA-GEP



LED Indicators

There are 3 LED outputs on the ZETA-xxP modem coloured Red, Green and Blue. By default, these show the functional/operational state of the modem. However, these may also be configured using software control by the user for other indication purposes. **Table 13** describes the functions of the LEDs.

Figure 14. ZETA-NLP and ZETA-NSP LEDs

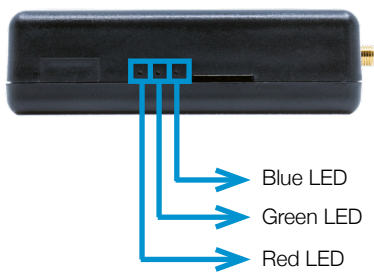

Figure 15. ZETA-NEP and ZETA-GEP LEDs

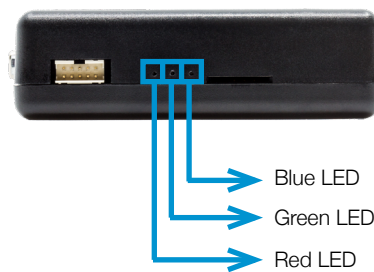

Table 13. LEDs

LED	At power up or PWRON_IN / PWROFF_IN control	After power up
Red	Undefined state	Network registration state / call indication
Green	Rapid blink during power on, otherwise off	Off / User defined
Blue	Rapid blink during power off, otherwise off	Off / User defined

Power Up LED States

On initial application of power, all LEDs will briefly illuminate. During power up, the green and blue LEDs are controlled directly by the ZETA-xxP power management controller, and the red LED is controlled by the embedded modem module. While the ZETA-xxP is in the power up state the green LED will flash rapidly (500 mS on, 500 mS off) and the Blue LED will be off until the power up process is complete.

ZETA-NLP Variants

After the power on process has completed, red, green and blue LED's are disabled completely to save power whilst it is in an operating state. The green LED will briefly flash once every 30 seconds to indicate that the modem is in the on.



ZETA-NSP, ZETA-NEP and ZETA-GEP Variants

After the power on process has completed, red, green and blue LED's are controlled directly by the module using the standard set of AT commands seen below.

Red LED User Control (Only available on ZETA-NSP, ZETA-NEP and ZETA-GEP variants)

ZETA-NSP, ZETA-NEP and ZETA-GEP AT Command to set network registration status

```
AT#GPIO=1,0,2
```

Turn on LED permanently

```
AT#GPIO=1,1,1
```

Turn off LED permanently

```
AT#GPIO=1,0,0
```

Green and Blue LED User Control (Not available on Ultra Low Power ZETA-NLP variants)

The green LED is connected to GPIO3 of the module and the blue to GPIO2. Both LEDs may be independently controlled as outputs using AT commands. The default setting is that these LEDs are off. **Table 14** shows the commands for changing the LED states. These settings are volatile and are lost when power is removed. More recent firmware releases have options to allow this setting to be made permanent.*

Table 14. Green and blue LED AT commands

LED	ON	OFF
Green	AT#GPIO=2,1,1	AT#GPIO=2,0,0
Blue	AT#GPIO=3,1,1	AT#GPIO=3,0,0

*Please read about the AT#GPIO command in the AT Commands Reference Guide for more information.



PWRON_IN Power On Procedure LED Indicators

PWRON_IN is the power on signal (pin 4 of the RJ12 power connector). Taking PWRON_IN high will turn the ZETA-xxP on (assuming there is power applied, but that the unit has been turned off using PWROFF_IN pin).

During power up, the green and blue LEDs are controlled directly by the ZETA-xxP power management process, and the red LED is controlled by the embedded modem module. While the ZETA-xxP is in the powering up process, the Green LED will flash rapidly (500 mS on, 500 mS off) and the Blue LED will be off until the power up process is complete.

ZETA-NLP Variants

After the power on process has completed, the red, green and blue LED's are disabled completely to save power whilst it is in an operating state. The green LED will briefly flash once every 30 seconds to indicate that the modem is on.

ZETA-NSP, ZETA-NEP and ZETA-GEP Variants

After the power on process has completed the red, green and blue LED's are controlled directly by the module using the standard set of AT commands described on [page 29](#).

PWROFF_IN Power Off Procedure LED Indications

PWROFF_IN is the power off signal on pin 3 of the RJ12 power connector. Taking PWROFF_IN high will turn a powered ZETA-xxP off.

During power off, the green and blue LEDs are controlled directly by the ZETA-xxP, and the red LED is controlled by the embedded modem module. While the ZETA-xxP is transitioning through the power off state the Blue LED will flash rapidly (500 mS on, 500 mS off) and the Green LED will be off until the power off process is complete when all LEDs will be off. In this state, PWRON_IN may be used to turn the unit on again.

ZETA-NLP Variants

After the power off process has completed, the Red, Green and Blue LED's are disabled completely. The blue LED will briefly flash once every 30 seconds to indicate that the modem is in the off state.

ZETA-NSP, ZETA-NEP and ZETA-GEP Variants

After the power off process has completed the Red, Green and Blue LED's are off.

Interfaces

RS232 Serial Port Interface

This connector provides a serial RS232 communication between the ZETA-xxP modem and the connected equipment. The modem can be configured via the RS232 connection using AT commands as specified in the AT command manual.

Figure 16. RS232 serial port



Figure 17. Pin numbering

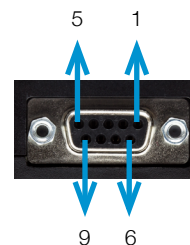

Table 15. Pin usage

Pin	Name	Usage	Status	Direction
1	DCD	Output from UART that indicates the carrier is present	Connected	OUT
2	RXD	Output transmit line of UART	Connected	OUT
3	TXD	Input receive line of UART	Connected	IN
4	DTR	Input to UART and controls DTE ready condition	Connected	IN
5	GND	Ground	Connected	IN
6	DSR	Output from UART that indicates the module is ready	Connected	OUT
7	RTS	Request to Send - Input line of UART that controls hardware flow control	Connected	IN
8	CTS	Clear to Send - Output line of UART that controls hardware flow control	Connected	OUT
9	RI	Ring Indicator - Output line of UART that indicates the incoming call condition	Connected	OUT

NOTE - Note that the ZETA-NLP has an ultra-low power mode of operation, which when enabled by de-asserting DTR will force all the RS232 output pins to be high impedance and not be driven. Only when DTR is asserted will the RS232 port be enabled.

Supported baudrates

» 2400	» 38400
» 4800	» 57600
» 9600	» 115200
» 19200	» 230400

USB Serial Port Interface

Figure 18. ZETA-xxP USB Connector

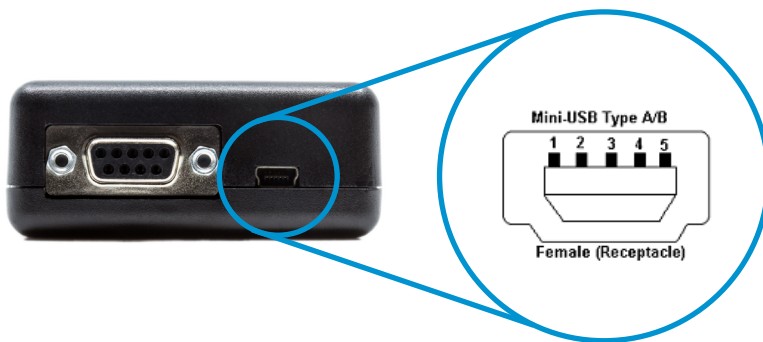

A mini USB type B connector is provided for USB serial connection. ESD protection to +/-4 KV contact discharge and +/-8 KV air discharge is provided. Pins on this connector are shown in **table 16** below.

Table 16. Mini USB Connectors

Pin	Name	Direction	Description	Low Level	Nominal	High Level
1	VBUS	Input	USB Power VBUS	4.75 V	5 V	5.25 V
2	D-	Differential	Data Minus	4.75 V	5 V	5.25 V
3	D+	Differential	Data Plus	4.75 V	5 V	5.25 V
4	-	-	-	-	-	-
5	GND	Input	Signal Ground	-	0 V	-



USB Interface Drivers

The ZETA-xxP series modems support a standard USB 2.0 device interface compatible with USB 2.0 specifications and supporting the USB low-speed [1.5 Mb/s] and full-Speed (12 Mb/s) modes. The USB port can be used to send AT-commands, reprogram the modems and view debug output. The maximum baud rate available to communicate with the ZETA-xxP series modems is up to 12 Mbit/s.

Drivers are required to use the USB port and are available for several operating systems including Windows/Linux. Please contact Siretta for more information.

In high speed LTE modes of operation, the downlink data speed rates can be higher than the maximum RS232 serial data rate. To achieve this network data rate using the ZETA-xxP, integrators need to interface the ZETA-xxP to their applications in full-speed (12 Mb/s) mode.

The device driver creates up to 6 virtual COM ports on the system for access to the module. 4 of these ports can be configured for use as general purpose AT command communication ports.

- USB0 → Configurable port *
- USB1 → Configurable port *
- USB2 → Configurable port *
- USB3 → Configurable port *
- USB4 → Configurable port *
- USB5 → Configurable port *

The ZETA-XxP series modems do not support autobauding. Integrators have to set the correct speed for serial communication before device initialization. If the right speed is set, the device responds with OK to any valid AT command.

The default baudrate is 115200.

To change the baudrate:

- » Send command `AT+IPR=<rate><cr>`
- » Wait for 'OK' response

*Please see the following command '`AT#PORTCFG`' to configure these ports on your modem.

Supported baudrates

» 300	» 115200
» 600	» 230400
» 1200	» 460800
» 2400	» 921600
» 4800	» 2900000
» 9600	» 3200000
» 19200	» 3686400
» 38400	» 4000000
» 57600	

GPIO 10-Way Connector

This connector provides a general purpose multi-way interface for the user to access additional functionality within the ZETA modem. This convenient interface allows connections to be made to the modems peripheral connections such as the trace / debug RS232 serial port, GPIO interface and ADC. Recommended mating connector: FCI 89947-710LF Receptacle Connector - IDC 2mm 2 x 5 - 10-way.

Figure 19. 10-way connector



Figure 20. Pin numbering

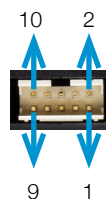

Figure 21. FCI 89947-710LF



Table 17. 10-way connector*

Pin	Name	Direction	Description	Low Level	Nominal	High Level
1	GND	Input	Signal Ground	-	0 V	-
2	Output 2	Output	General Purpose Output 2	0 - 0.5 V	12 V	VCC
3	Debug RX	Input	Debug Serial Receive (TTL)	-25 V		25 V
4	Output 1	Output	General Purpose Output 1	0 - 0.5 V	12 V	VCC
5	Debug TX	Output	Debug Serial Transmit (TTL)	-5 V		5 V
6	Input 3	Input	General Purpose Input 3	0 - 0.5 V	12 V	42 V
7	VIN_OUT	Output	Power Supply Voltage Output		VIN*	
8	Input 2	Input	General Purpose Input 2	0 - 0.5 V	12 V	42 V
9	ADC 1	Input	Analogue to Digital Converter 1	0 - 0.5 V	12 V	42 V
10	Input 1	Input	General Purpose Input 1	0 - 0.5 V	12 V	42 V

*Important information regarding 10-Way connector, pin 7:
 Devices with batch code 44055 or greater output VIN on pin 7
 Devices with batch code less than 44055 output 3.3 V on pin 7

The batch code can be found on the silver label on the back of the ZETA-xxP modem.

SIM Socket

The ZETA-xxP modem supports fixed SIMs locked to a network and roaming SIMs which can operate on more than one network within the home country. This allows for least cost routing for roaming mobile data and machine to machine applications where signal strength is variable in any given area and network selection is required.

The ZETA-xxP also supports global roaming SIMs which will work with any network it can detect, at home or abroad and can be chosen for best performance.

Figure 22. ZETA-NLP and ZETA-NSP - SIM holder



SIM Requirements

SIM services available for the ZETA-xxP-LTE series include:

- » 2G GSM (850 MHz, 900 MHz, 1800 MHz, 1900 MHz)
- » LTE Cat M1 / NB1 (700 MHz, 800 MHz, 850 MHz, 900 MHz, 1700 MHz, 1800 MHz, 1900 MHz, 2100 MHz)
- » 4G LTE (700 MHz, 800 MHz, 900 MHz, 1800 MHz, 2100 MHz, 2600 MHz)
- » SMS
- » GPRS
- » CSD (optional on GSM/UMTS)



Digital Functions

The ZETA-xxP maximum current drive on the outputs and current consumption on the inputs are shown below in **table 18**.

Table 18. Input/Output voltages

Signal Name	Parameter	Voltage Level	Current Source / Sink
Input 1	Input current	VCC	0.31 mA
Input 2	Input current	VCC	0.31 mA
Input 3	Input current	VCC	0.31 mA
Output 1	Current sink	VCC	1.0 A
Output 2	Current sink	VCC	1.0 A
ADC	Input current	VCC	4.2 mA
3.3V Output	Power supply	3.3 V	100 mA

Digital Output

- » See **table 18** above for maximum output current
- » Under full control of AT command/embedded application

The following commands can be used to initialise and to set the digital output functionality:

AT#GPIO=4,1,1 (switch general purpose output 1 on, Pin 4 on function header)

AT#GPIO=4,0,1 (switch general purpose output 1 off, Pin 4 on function header)

AT#GPIO=5,1,1 (switch general purpose output 2 on, Pin 2 on function header)

AT#GPIO=5,0,1 (switch general purpose output 2 off, Pin 2 on function header)



Digital Input

» Under full control of embedded application

The following AT commands can be used to initialise and to read the status of the general purpose inputs:

AT#GPIO=6,2,0 (read general purpose input 1, Pin 10 on function header)

AT#GPIO=7,2,0 (read general purpose input 2, Pin 8 on function header)

AT#GPIO=8,2,0 (read general purpose input 3, Pin 6 on function header)

Configuration Switch (Emergency Boot)

NOTE: This mode of operation is not required for normal operation. Emergency boot mode should only ever be attempted when the modem is in a non working state and appears to be unrecoverable using the normal firmware update process. In this scenario please use the emergency boot process to get the modem in to a special baseline firmware programming state.

The status of the configuration switch is detected when power is applied. Pressing the switch after power has been applied has no effect. It will take a second or so between applying power and the switch press being detected. Indication that the ZETA-xxP modem has detected the emergency boot switch press is shown in the device manager with a new base device called 'QDLoader' appearing in the device list. Press the switch using the supplied 'Siretta Function Pin Tool'.

Once emergency boot mode has been selected, the module will remain in this idle emergency boot state until one of the following actions is taken:

- » Firmware Update: Run the firmware update procedure to reflash the firmware running on the module. Allow the entire update procedure to complete before powering down the module.
- » Device Reboot: Power down the module and reboot. If the device has entered a non working state then the emergency boot mode may be required to allow you to be able to reflash the device firmware correctly.

This emergency boot mode is equivalent to a device reset state. Normal modem operation will not be possible when the modem has entered this state and the modem must be reflashed or rebooted for normal operation to be available. Please contact your Siretta representative for more information.

Figure 23. Configuration switch (Emergency boot)

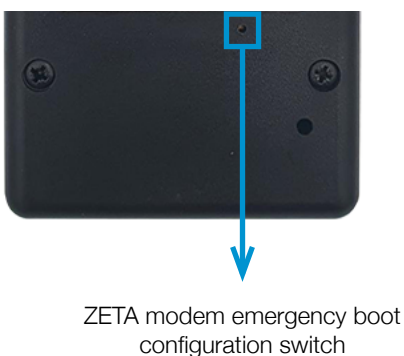

Figure 24. Siretta Function Pin Tool



Antenna Connectors

Figure 25. ZETA-NxP Antenna Connectors

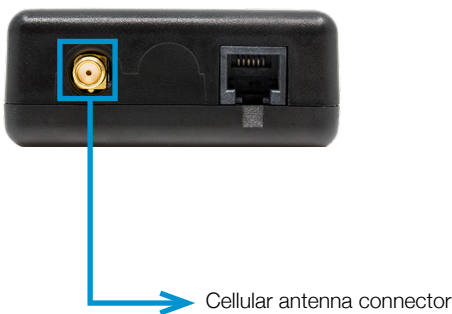
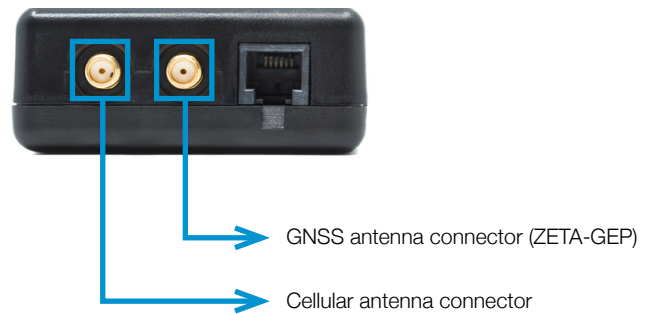

Figure 26. ZETA-GEP Antenna Connectors



Antenna Placement

When in service the antenna should be placed away from electronic devices or other antennas. The recommended minimum distance between adjacent antennas, operating on a similar radio band, is at least 50 cm. The antenna should not be placed inside a metal box.

Please read the antenna manufacturers installation instructions carefully - some antennas require a ground plane.

If getting good reception is a problem, try raising the height at which the antenna is installed. Increasing the elevation is usually the best way to improve the received signal strength.

Antenna Connection Cable

If a cable is used to connect the modem to the antenna this cable must be a high quality low loss cable. The cable and any connectors used should have 50 ohms impedance.



Cellular Antenna Connector

For correct operation of the ZETA, to fulfil all regulatory requirements and prevent damage, the antenna connected must meet the following requirements:

- » Frequency range: Select an antenna that covers all the frequency bands supported by the ZETA. This will depend on which regional version of the ZETA that you have purchased.
- » Gain absolute maximum: 3 dBi
- » Gain recommended: < 2 dBi
- » Impedance: 50 Ohm
- » Input Power: > 33 dBm (2W) peak power in GSM
> 24 dBm average power in UMTS & LTE
- » VSWR absolute maximum: <= 10:1 (to prevent damage)
- » VSWR recommended: <= 2:1 (to fulfil regulatory requirements)



GNSS Antenna Connector (ZETA-GEP Models)

GNSS Antenna Polarization

The GNSS signal as broadcast is a right hand circularly polarized signal. The best antenna to receive the GNSS signal is a right hand circularly (RHCP) polarized patch antenna.

GNSS Antenna Gain

Antenna gain is defined as the extra signal power from the antenna as compared to a theoretical isotropic antenna (equally sensitive in all directions).

It is important to note that GNSS antenna gain is not the same as external LNA gain. Most antenna vendors will specify these numbers separately, but some combine them into a single number. It is important to know both numbers when designing and evaluating the front end of a GNSS receiver.

An antenna with higher gain will generally outperform an antenna with lower gain. Once the signals are above about -130 dBm for a particular satellite, no improvement in performance would be gained. However, for those satellites that are below about -125 dBm, a higher gain antenna would improve the gain and improve the performance of the GNSS receiver. In the case of really weak signals, a good antenna could mean the difference between being able to use a particular satellite signal or not.

As the GNSS antenna ideally should be located away from the ZETA-xxP modem series then an active antenna will be required to obtain the best system performance. The active antenna has its own built in low noise amplifier to overcome RF trace or cable losses after the active antenna. The active antenna has a low noise amplifier (LNA) with associated gain and noise figure.



GNSS

ZETA-GEP Modem

The ZETA-GEP modem has a cutting edge GNSS receiver that can simultaneously search and track satellite signals from multiple satellite constellations.

This multi-GNSS receiver uses the entire spectrum of Global Navigation Satellite Systems to support the following constellations:

- » GPS
- » Glonass
- » Beidou
- » Galileo
- » QZSS

The ZETA-GEP's high performance GNSS receiver provides:

- » Advanced real time hardware correlation engine for enhanced sensitivity navigation (PVT)
- » Fast Acquisition giving rapid Time-to-First-Fix (TTFF)
- » Low power consumption
- » 32 track verification channels
- » Stand Alone tracking
- » Assisted mode tracking
- » GNSS sensitivity better than -157 dBm enabling indoor tracking applications
- » Satellite Based Augmentation Systems (SBAS)
- » Wide Area Augmentation System (WAAS)
- » European Geostationary Navigation Overlay Service (EGNOS)
- » Multi-functional Satellite Augmentation System (MSAS)



GNSS Power Supply

The GNSS antenna power supply is generated internally by the ZETA-xxP modem and is a stable high accuracy low dropout supply designed to give very good GNSS performance.

Table 19. GNSS power consumption

Characteristic	Typical Values
Power Consumption in Acquisition	16.4 mA *
Power Consumption in Tracking	12.8 mA *
Power Consumption in Low Power Tracking	5.7 mA *

GNSS Output Power

Table 20. GNSS antenna power supply output characteristics

	Min	Nom	Max
Output enabled	3.2 V	3.3 V	3.4 V
Output disabled	-	0.0 V	0.2 V
Output current	0 mA	20 mA	100 mA

NOTE - Power supply is enabled when GNSS engine is powered with the following AT command:

AT\$GPSP=1 - will turn the GNSS engine on

AT\$GPSP=0 - will turn the GNSS engine off

To output NMEA data, please refer to AT\$GPSNMUN command in the AT command reference guide.

* GNSS Power consumption figures are taken whilst modem is operating at 12 V.

Power

RJ12 Power Connector

This connector is used for supplying DC power and power ON/OFF signals for the modem.

Figure 27. ZETA-xxP - RJ12 power connector

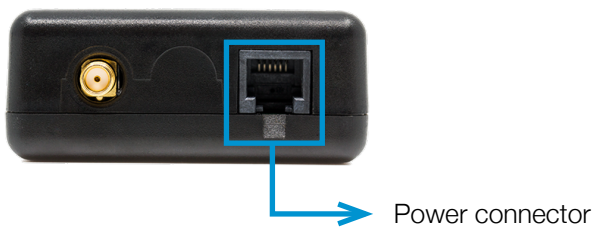

Figure 28. Pin numbering

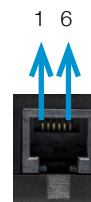

Table 21. Pin usage

Pin	Name	Function	Description
1	V_IN	Power	Input power (7 V to 42 V; 12 V @ 1 A recommended)
2	RESET_IN	Input	Hard System Reset
3	PWROFF_IN	Input	Power off signal
4	PWRON_IN	Input	Power on signal
5	Reserved	Input	Unused input
6	GND	Power	Ground

1.75 V is enough to activate the inputs.



Table 22. Input pin parameters

Name	Conditions	Min	Typ	Max	Units
Maximum input voltage				42	Volts
Input threshold low				0.25	Volts
Input threshold high		1.75			Volts
Input resistance	+25 °C	23.5		47	kΩ

All characteristics are over the operating temperature range of -40 to +85 °C unless stated otherwise.

All signal input pins have an internal 47K Ohm pull down to ground, so it is acceptable to leave them disconnected if unused. This is their inactive (off) state.

The modem ON/OFF state is activated by the power OFF and power ON signal inputs.

The modem ON/OFF states are shown in **table 24**. The initial state of the modem on power-up is ON.



Power Supply Requirements

A DC power supply must be connected to the power input.

Table 23. Characteristics of power input

	ZETA-xxP Series
DC input voltage	7 to 42 V
Recommended input voltage	12 V DC
Supply current @ 12V:	
Peak (20ms at registration)	1 A
Average standby	11 mA
Call in progress	200 mA
Ringing	210 mA
GNSS enabled	16 mA

The ZETA-xxP modem has a wide operating voltage and can be powered from 7V to 42V. Powering the modem can be done in 2 different ways:

- » Modem Power Supply - Standard multi region power supply provides constant 12 V at 1 A. The ZETA-xEP modems have an additional 10 way connector that can also supply power. If using this connector, any current taken from this connector needs to be added to the current rating of the power supply used to power the modem.

A suitable mains power supply is included as part of the starter kit, or may be ordered separately as part number 60942.

- » Power Cable - Provide an external DC power source between 7 V to 42 V.

A suitable cable, 1m long and terminated with an RJ12 connector, is included as part of the starter kit. It may be ordered separately as part number 61064.

The RJ12 connector used to apply power to the ZETA is a polarised connector. As a consequence, no reverse voltage protection has been provided for the ZETA modem. The power supply input does have ESD protection and is able to withstand a Human Body Model transient pulse of +/-2500 V per JEDEC JESD22-A114.

The current requirements of the ZETA-xxP modem will scale with input voltage. The higher the input voltage the lower the current consumption, the power consumption will remain constant. Recommended input voltage is 12 V.



Table 24. ZETA-xxP modem states

ZETA-xxP State	Pin-4 (ON)	Pin-3 (OFF)	Modem ON/OFF
OFF	ACTIVE	ACTIVE	OFF
ON	ACTIVE	ACTIVE	ON
ON	NOT-ACTIVE	ACTIVE	Switches OFF
OFF	NOT-ACTIVE	ACTIVE	OFF
OFF	ACTIVE	NOT-ACTIVE	Switches ON
ON	ACTIVE	NOT-ACTIVE	ON



Switching the Modem ON/OFF

Power on the ZETA-xxP

The ZETA-xxP modems have several options to power on. The 2 main options are shown below:

- 1) Auto power up using the built in power controller. This process is controlled by default within the modem to control the modem functionality and allows for automatic power up when power is supplied. The auto power on control will automatically power up the modem as required and manage its status whilst it is online.
- 2) Manually power up the modem using the PWRON_IN pin on the RJ12 power connector (Pin 4). When this pin is connected to logic high (1.75 V – 42 V) for >0.5 seconds the modem will power up.

NOTE - The modem is fully operational after it has powered on and able to send AT commands. This may take anything from 2 to 40 seconds depending on the startup procedure. to connect to the fastest available network and will fallback to slower networks as available. This may take control of the modem and is network and technology dependant.

Power off the ZETA-xxP

The ZETA-xxP modems have one option to power off as shown below:

- 1) Manually power down the modem using the PWROFF_IN pin on the RJ12 power connector (Pin 3). When this pin is connected to logic high (1.75 V – 42 V) for >0.5 seconds the modem will power off.



Considerations when manually powering the ZETA-xxP on and off

The PWRON_IN and PWROFF_IN signals requires a positive “edge” (a “sharp” signal transition from low to high) to turn the modem on. This transition should be a rising signal from 0 V (GND) up to at least 1.75 V. Very slow transitions (significantly slower than many milliseconds) or very small transitions (e.g. only a few millivolts instead of 0 V to 1.75 V) will not turn on the modem (since they are not considered to be a “positive edge”).

Although this will not be an issue in almost all typical applications of the modem, under the following condition special design care has to be taken:

- » Large capacitors in your power supply which will lead to slow leading and falling edges

The case above might prevent the modem from recognizing the power-up signal. This is no failure of the modem itself, the same would apply to almost any electronic device that provides a separate “power-on” or “reset” signal.

If you are in doubt, please use the following recommendations:

- » Use the Vcc power supply signal from the main supply to test the power on signal function.
- » Make sure that your signal and system design adheres to the recommendations mentioned above
- » Consult our support team and we will be more than happy to assist you.

Disaster recovery power down reset procedure

The ZETA-xxP modems have a special power down reset function for disaster recovery.

In the event of the standard power down functions failing using the PWROFF_IN pin or the modem becoming unresponsive then you can apply a modem reset using the RESET_IN pin. When this pin is connected to logic high (1.75 V – 42 V) for >0.5 seconds the modem will be reset.

Alternatively power can be removed completely from the modem. Wait for a minimum of 10 seconds and then apply mains power to put the modem in to the startup state.

NOTE - Powering down the modem without following the correct procedure using the shutdown command or the hardware PWROFF_IN pin can result in improper functioning of the modem. It will also not detach safely from the Cellular network and may cause the modem to become blacklisted.



Recovery Boot Mode

ZETA-xxP-LTE models (and not ZETA-xxP-LTEM models) have an emergency boot download mode that may be used in the case that corrupted boot image was flashed into the device or in case all other recovery modes fail to work.

Emergency download mode is triggered by first removing power to the ZETA, pressing and holding down the recessed recovery boot mode switch (by using a power clip or similar), reapplying power, and then releasing the switch 10 seconds after power has been reapplied.

ZETA-NLP Power Enhancements

The ZETA-NLP has been designed to operate in an ultra low power state as standard. There have been a number of enhancements made to the functional operation of the unit to help accommodate low power operation in normal use. When running in full power mode the unit makes use of a very efficient power supply and all components have been optimized for reduced current loss across the entire design.



ZETA-NLP Ultra Low Power Mode

The ZETA-NLP has a special mode of operation which forces the unit to drop down to a ultra low power state where the modem is still operational and registered on the network but is functionally asleep. This allows for the modem to remain connected to the network and be ready to send and receive data using a fraction of the energy. This mode works when using the RS232 serial port as the sole communication interface - the USB port must be left disconnected while the Ultra Low Power Mode is being used.

This ultra low power state is achieved by setting the following AT command to the modem:

```
AT+CFUN=5
```

Once this command has been issued then the modem is ready to enter ultra low power mode. To activate low power mode and put the modem in to a dormant state the DTR line must be de-asserted on the serial port.

When the device has entered ultra low power mode the CTS line will be de-asserted indicating that the device has gone into ultra low power state. At this point the serial port is also deactivated and the modem will not respond to AT commands and will appear to be off. To bring the modem back to normal power state and communicate with the modem again it is necessary to assert the DTR line and the modem will leave its dormant state and become fully active again for normal operation. When in the dormant ultra low power state an incoming call request or incoming SMS will force the modem to enter its full power mode and the modem is able to be used as normal.

This mode allows the modem to consume very little current whilst it is not in use but be available for use locally by asserting the DTR line. The modem power on and power lines will remain active throughout and can also be used to turn the modem completely off.



Low Power Mode Receiving Data

In the ultra low power state a special provision must be catered for when data is received from a connected socket to be output over the serial port.

In this mode it is necessary to run the serial port in the following state:

1. Enable hardware flow control with AT&K3
2. Enable low power mode by issuing AT+CFUN=5
3. Setup a socket connection and establish an active connection
4. Enter ultra low power state by de-asserting DTR control line
5. De-assert RTS line
6. Wait for specified timeout to check for incoming data

When the timeout has expired, to check for data over the connected socket follow the procedure below:

1. Assert DTR line to disable low power state and activate full serial port
2. Assert RTS line to receive full buffered data over serial port and wait for all data to be received
3. When all data has been received de-assert RTS line
4. De-assert DTR line to re-enter low power state and wait for the specified timeout to receive further data

Low Power Incoming Data Process Cycle

Follow process flow below to receive incoming data over the cellular network when running in low power state where the timeout has expired and data is ready to be received.

Check for data from the cellular network using the active connection

- >> Assert DTR
- >> Assert RTS
- < Receive incoming data >
- >> De-assert RTS
- >> De-assert DTR

Wait for timeout to check for incoming data from the cellular network connection.

NOTE - While there is no data pending reception from the cellular network, the modem does meet the published low power consumption figures. However, if there is data pending from the cellular network, then the modem power consumption rises to approximately 5 mA at 12 V until the data transfer process has completed and low power state is re-entered.

The modem does not automatically enter the full power state when there is pending cellular network data, so the connected application is required to periodically poll the cellular network. If there is pending data from the cellular network, this will immediately start to be received over the serial connection. Once the data transfer is complete, the modem can be put back into the low power state where it will meet the published power consumption figures.

The shorter the check interval, the less time will be potentially spent at the higher 5mA current consumption. The longer the check interval the less power will be used checking for received data from the network. Choose this check interval to match the requirements of your system.



Embedded Software Support

When developing your application you may decide to use an external micro controller to manage your applications functionality. Depending on your exact requirements you may need to have the added flexibility of using an external microprocessor to manage power constraints or enable high performance functionality. You also have the option to use the embedded software development environment included within the cellular engine on the Siretta ZETA-xxP modems. All the modules used within the ZETA-xxP modems support the Telit IoT AppZone embedded development environment which is available for use out-of-the-box and can be developed to suit your exact application requirements.

NOTE - Contact your Siretta representative for information about these 2 programming environments.

Telit AppZone

Telit AppZone is a high-level optimized standard C development environment that has been developed as an integrated platform to run within the cellular module and provides an advantageous “all-in-one” solution. This allows you to save time and money because the M2M module can perform all the key tasks normally associated with an external microprocessor.

The development environment offers a flexible platform whether you are planning on developing a new tracking application, an innovative healthcare device, a trend-setting Automatic Meter Reading component or any other M2M application. The Telit AppZone could meet your needs whilst minimizing your development effort and design costs. The end result is a much faster TTM (Time to Market).

Some of the key distinguishing features of AppZone include:

- » Fast Interrupt Latency (130 μ sec)
- » AT command tunneling
- » Multi-tasking with IPC feature and application priority
- » Over-The-Air (OTA) updates
- » Low power consumption (Deep Sleep mode 75 μ A)
- » File System and memory (FS NVM, Flash and RAM)



Telit AppZone - Lightweight, fast and efficient

AppZone lets you take full advantage of the hardware features and capabilities of your Siretta modem, enabling software development across product families. The AppZone IDE is the reference workbench and development tool for all Telit based products, supporting the multiple programming environments available for different modules and technologies

AppZone C is the flagship application framework for cellular products. It is lightweight, runs on RTOS and delivers optimized performances and fast response. The framework includes a full set of APIs programmable in C language, enabling access to the modem, hardware, peripherals, operating system and other services. Ease of integration of 3rd party libraries, protocol stacks and peripherals. Available across all cellular technologies and form factors.

IoT AppZone supports Python for Telit legacy modules.



Installation

Considerations for Installations Incorporating the ZETA-xxP

There are several conditions which need to be taken into consideration when designing your application as they might affect the modem and its functionality. These are:

Environmental conditions: The modem must be installed so that the environmental conditions stated such as temperature, humidity and vibration are satisfied. Additionally, the electrical specifications must not be exceeded.

Cellular signal strength: The modem/antenna has to be placed in a position that ensures sufficient cellular signal strength. To improve signal strength, the antenna can be moved to a more elevated position. Signal strength usually depends on how close the modem is to cellular base station. You must ensure that the location at which you intend to use the modem is within the network coverage area. Degradation in signal strength can be the result of a disturbance from another source, for example an electronic device in the immediate vicinity.

When the application is operational, you can verify signal strength by issuing the AT command:

AT+CSQ

See “AT+CSQ Signal Strength” in the AT command manual

*Tip: Before installing the modem you can use an ordinary mobile telephone to check the signal strength in each possible installation location. Siretta can also provide a cellular signal tester which provides a full breakdown of the cellular signal received.**

When considering the location for the modem and antenna placement, you must consider received signal strength as well as cable length as long cable runs can attenuate the received signal strength.

Connections of components to ZETA-xxP Series modems: The system integrator is responsible for the final system solution. If external components are incorrectly designed or installed it may cause radiation limits to be exceeded. For instance, improper cable connections or incorrectly installed antennas can disturb the network and lead to modem malfunction.

*Please contact your Siretta representative for more information



Network and subscription: Before your application is used, you must ensure that your chosen network provides the necessary telecommunication services. Contact your service provider to obtain the necessary information.

- » If you intend to use SMS in the application, ensure this is included in your SIM subscription.
- » Consider which network technologies are available in your region and the impact this will have on device connectivity. 2G/GSM, 3G/UMTS, LTE Cat 1/4, LTE Cat M1 and LTE Cat NB1 all operate in different ways. As a result they all have different advantages and disadvantages and as such may be suited to different application types.

Power Supply Installations

- » Use a high-quality power supply with short leads. This ensures that the voltages at the connector pins are within the specified range, especially during the maximum peak current of approximately 1 A.
- » When the modem is powered from a battery or a high current supply, connect a fast 1.25 A fuse in line with the positive supply. This protects the power cabling and modem from damage.

Securing the Modem

Before securing the modem please take into account the amount of additional space required for the mating connectors and cables that will be used with the modem in the application.

- » Where access is restricted, it may be easier to connect all the cables to the modem prior to placing it in the application on the headers.
- » Securely attach the ZETA-xxP modem to the host application using 4 x M3 (3 mm diameter) pan-head screws.
- » Securely attach the ZETA-xxP modem using the optional ZETA Modem DIN Rail Adapter mounting bracket (Datasheet available here).



Regulatory Approvals



Device ID 2AVL4ZETA-XXP

This device complies with part 15 of the FCC Rules. Operation is subject to the following two conditions: (1) This device may not cause harmful interference, and (2) this device must accept any interference received, including interference that may cause undesired operation.

Any changes or modifications not expressly approved by the party responsible for compliance could void the user's authority to operate the equipment.

Note: This equipment has been tested and found to comply with the limits for a Class B digital device, pursuant to part 15 of the FCC Rules. These limits are designed to provide reasonable protection against harmful interference in a residential installation. This equipment generates uses and can radiate radio frequency energy and, if not installed and used in accordance with the instructions, may cause harmful interference to radio communications. However, there is no guarantee that interference will not occur in a particular installation. If this equipment does cause harmful interference to radio or television reception, which can be determined by turning the equipment off and on, the user is encouraged to try to correct the interference by one or more of the following measures:

- » Re-orient or relocate the receiving antenna.
- » Increase the separation between the equipment and receiver.
- » Connect the equipment into an outlet on a circuit different from that to which the receiver is connected.
- » Consult the dealer or an experienced radio/TV technician for help.

This equipment complies with FCC radiation exposure limits set forth for an uncontrolled environment. This equipment should be installed and operated with minimum distance 20cm between the radiator and your body.



The product complies with the requirements of the following directives:

The Radio Equipment Directive 2014/53/EU

The RoHS Regulations 2011/65/EU



The product complies with the requirements of the following regulations:

The Radio Equipment Regulations 2017; UK SI 2017 no. 1206

The RoHS Regulations 2012; UK SI 2012 No 3032



Device ID 28712-ZETAXXP

This device contains licence-exempt transmitter(s)/receiver(s) that comply with Innovation, Science and Economic Development Canada's licence-exempt RSS(s). Operation is subject to the following two conditions:

- (1) This device may not cause interference.
- (2) This device must accept any interference, including interference that may cause undesired operation of the device.

L'émetteur/récepteur exempt de licence contenu dans le présent appareil est conforme aux CNR d'Innovation, Sciences et Développement économique Canada applicables aux appareils radio exempts de licence. L'exploitation est autorisée aux deux conditions suivantes :

- 1) L'appareil ne doit pas produire de brouillage;
- 2) L'appareil doit accepter tout brouillage radioélectrique subi, même si le brouillage est susceptible d'en compromettre le fonctionnement.



This equipment should be installed and operated with a minimum distance of 20 centimeters between the radiator and your body.

Cet équipement devrait être installé et actionné avec une distance minimum de 20 centimètres entre le radiateur et votre corps.

Responsible Party – Contact Information

Declarations of Conformity are provided to all competent authorities by:

Siretta Limited
Basingstoke Road
Spencers Wood
Reading
Berkshire
RG7 1PW
+44 1189 769 000
support@siretta.com

The approvals mentioned are valid only if the appropriate marking has been affixed to the product. To find out which approvals have been granted to the product, please refer to the markings on the product label.



Safety and Product Care

Please read the information in this section, before you begin your system integration.

General Precautions

- » The ZETA-xxP series modems are a standalone item designed for indoor use only. For use outside it must be installed in a weatherproof enclosure.
- » Do not exceed the environmental and electrical limits as specified.
- » Avoid exposing the modem to lit cigarettes, naked flames or to extreme hot or cold temperatures.
- » Never try to dismantle the modem. There are no components inside the modem that can be serviced by the user. If you attempt to dismantle the modem, you will invalidate the warranty.
- » The ZETA-xxP series modems must not be installed or located where the surface temperature of the enclosure may exceed 85 °C.
- » All cables connected to the ZETA-xxP series modems must be secured or clamped, immediately adjacent to the modems connectors, to provide strain relief and to avoid transmitting excessive vibration to the modem in the installation.
- » To protect power supply and to meet the fire safety requirements when the modem is powered from a battery or a high current supply, connect a fast 1.2 5A fuse in line with the positive supply.
- » Do not connect any incompatible component or product to the ZETA-xxP series modem.

SIM Card Precautions

Before handling the SIM card in your application, ensure that you have discharged any static electricity. Use standard precautions to avoid electrostatic discharges.

- » When designing a ZETA-xxP series modem into your application, the accessibility of the SIM card should be taken into account so that it can be removed or changed.



Antenna Precautions

If the antenna is to be mounted outside, always consider the risk of a lightning strike. Follow the instructions provided by the antenna manufacturer. In addition please observe the following:

- » Never connect more than one modem to a single antenna. The modem can be damaged by radio frequency energy from the transmitter of another modem.
- » With all mobile station equipment, the antenna of the modem emits radio frequency energy. To avoid EMI (electromagnetic interference) you must determine if the application or equipment in the application's proximity, needs further protection against radio emission and the disturbances it might cause. Protection is secured either by shielding the surrounding electronics or by moving the antenna away from the electronics and external signal cables.
- » The modem and antenna may be damaged if either come into contact with ground potentials other than the ground potential used in your application. Beware, ground potentials can vary significantly between hardware platforms.

Exposure to RF Energy

There has been some public concern about possible health effects of using cellular equipment in close proximity to a person or body. Although research on health effects from RF energy has focused for many years on the current RF technology, research has begun on new radio technologies, such as LTE and 5G. After existing research had been reviewed, and after compliance to all applicable safety standards has been tested, it has been concluded that the ZETA-xxP series modem is fit for use.

If you are concerned about exposure to RF energy, there are a number of things you can do to minimize exposure. Obviously, limiting the duration of time near a device will reduce your exposure to RF energy. In addition, you can reduce RF exposure by operating your modem efficiently by adhering to the following guidelines:

Electronic devices: Most electronic equipment, for example in hospitals and motor vehicles is shielded from RF energy. However, RF energy may affect some malfunctioning or improperly shielded electronic equipment.

Vehicle electronic equipment: Check your vehicle manufacturer's representative to determine if any on board electronic equipment is adequately shielded from external RF energy.



Aircraft: Turn your modem OFF before boarding any aircraft. To prevent possible interference with aircraft systems, Federal Aviation Administration (FAA) regulations require you to have permission from a crewmember to use your modem equipment whilst the plane is on the ground. To prevent interference with cellular systems, local RF regulations prohibit using your modem whilst in the air.

Blasting areas: To avoid interfering with blasting operations, turn your modem OFF when in a “blasting area” or in areas posted: “turn off two-way radio“. Construction crew often uses remote control RF devices to set off explosives.

Potentially explosive atmospheres: Turn your modem OFF when in any area with a potentially explosive atmosphere. It is rare, but your modems or their accessories could generate sparks. Sparks in such areas could cause an explosion or fire resulting in bodily injury or even death.

Areas with a potentially explosive atmosphere are often, but not always, clearly marked. They include fuelling areas such as petrol stations, below deck on boats, fuel or chemical transfer or storage facilities and areas where the air contains chemicals or particles, such as grain, dust or metal powders. Do not transport or store flammable gas, liquid or explosives, in the compartment of your vehicle, which contains your modem or accessories. Before using your modem in a vehicle powered by liquefied petroleum gas (such as propane or butane) ensure that the vehicle complies with the relevant fire and safety regulations of the country in which the vehicle is to be used.



Safety Recommendations

PLEASE READ CAREFULLY

Be sure the use of this product is allowed in the country intended and the environment required. The use of this product may be dangerous and has to be used with caution in the following areas:

- » Where it can interfere with other electronic devices in environments such as hospitals, airports, aircrafts, etc
- » Where there is risk of explosion such as gasoline stations, oil refineries, gas works etc

It is responsibility of the user to enforce the country regulation and the specific environment regulation.

Do not disassemble the product, any mark of tampering will compromise the warranty.

We recommend following the instructions of this hardware user guide for the correct wiring of the product. The product has to be supplied with a stabilized voltage source and the wiring has to conform to the security and fire prevention regulations.

The product has to be handled with care, avoid any direct contact with the pins because electrostatic discharge may damage the product. The same precautions have to be observed for the SIM card installation. Do not insert or remove the SIM when the product is in power saving mode. (AT+CFUN=5).

The system integrator is responsible for the complete functionality of the final product. Therefore, care has to be taken with the external components used with the module, as well as any installation issue.

Should there be any doubt, please refer to the technical documentation and the regulations in force. Every module has to be equipped with a suitable antenna with characteristics which match the product requirements.

The antenna has to be installed with care in order to avoid any interference with other electronic devices and has to guarantee a minimum distance from the body (20 cm). In case this requirement cannot be satisfied, the system integrator has to assess the final product against the SAR regulation EN 50360.



Conformity Assessment

The ZETA-xxP series of modems conform to the R&TTE Directive for use as a stand-alone product. If the modem is installed in compliance with the telecoms installation instructions then no further evaluation is required under Article 3.2 of the R&TTE Directive and no further involvement of an R&TTE Directive Notified Body is required for the final application.

The ZETA-xxP series of modems conform to the following European Union Directives:

- » R&TTE Directive 1999/5/EC (Radio Equipment & Telecommunications Terminal Equipment)
- » LVD (Low Voltage Directive) 73/23/EEC and product safety
- » Directive 89/336/EEC for conformity for EMC

In order to satisfy the essential requisite of the R&TTE 99/5/EC directive, the ZETA-xxP series modems are compliant with the following standards:

- » GSM (Radio Spectrum). Standard: EN 301 511 and 3GPP 51.010-1
- » EMC (Electromagnetic Compatibility). Standards: EN 301 489-1 and EN 301 489-7
- » Include stand-alone spurious emissions to Clause 8.2 of EN 301 489-1.
- » LVD (Low Voltage Directive) Standards: EN 60 950



Disclaimer

The information contained in this document is proprietary to Siretta. Siretta has made every effort to ensure that the accuracy of the information contained within this document is accurate. Siretta does not make any warranty as to the information contained within this document and does not accept any liability for any injury, loss or damage of any kind incurred by the use of this information.

Siretta does not take responsibility for any application developed using the modem characterized in this document and notes that any application of this modem must comply with the safety standards of the applicable country and comply with the relevant wiring rules. Siretta reserves the right to make modifications, additions and deletions to this document due to typographical errors, inaccurate information, or improvements to equipment at any time and without notice. Such changes will be incorporated into new editions of this document.
All rights reserved.

Please refer to the [Siretta Ltd](https://www.siretta.com) website for the latest version of this document.

© 2024 Siretta Ltd



Definitions

Term	Definition
2G	2nd Generation Mobile Telecommunications
3G	3rd Generation Mobile Telecommunications
4G	4th Generation Mobile Telecommunications
5G	5th Generation Mobile Telecommunications
ADC	Analog to Digital Converter
AMR	Automatic Meter Reading
AT	Attention
Cat 1	LTE Category 1 Network
Cat 4	LTE Category 4 Network
Cat M1	LTE Category M Network
Cat NB1	LTE Narrow Band Internet of Things Network
CBS	Cell Broadcasting Service
CSD	Circuit Switched Data
CTS	Clear To Send
DCD	Data Carrier Detect
DSR	Data Set Ready
DTR	Data Terminal Ready
GND	Ground
GPI	General Purpose Input
GPIO	General Purpose Input Output
GPO	General Purpose Output
GPRS	General Packet Radio Service
GPS	Global Positioning System
GSM	Global System for Mobile Communications

I/O	Input/Output
IoE	Internet of Everything
IoT	Internet of Things
LED	Light Emitting Diode
LTE	Long Term Evolution
M2M	Machine to Machine
MMS	Multimedia Messaging Service
RF	Radio Frequency
RI	Ring Indicator
RS232	Recommended Standard 232
RTS	Request to Send
RX	Receive Signal
RXD	Receive Signal
SIM	Subscriber Identity Module
SMA	Sub Miniature Version A
SMS	Short Message Service
TTF	Time To First Fix
TTL	Transistor - Transistor Logic
TX	Transmit Signal
TXD	Transmit Signal
UMTS	Universal Mobile Telecommunications System (Same as 3G)
USB	Universal Serial Bus
Vcc	Positive Power Supply
Vin	Input voltage



Enabling Industrial IoT

sales +44 (0)118 976 9000

email sales@siretta.com

www.siretta.com

Siretta Ltd
Basingstoke Road
Spencers Wood
Reading
Berkshire
RG7 1PW
United Kingdom

Company No. 08405712
VAT Registration No. GB163 04 0349

