



Enabling Industrial IoT



## SENTRY

Remote Continuous Survey LTE Logger

Applicable models:

SENTRY-G-LTE4 (EU)

SENTRY-G-LTE4 (USA)

### User Manual

Rev 1.1



## Table of Contents

<b>Introduction</b>	<b>3</b>
<b>Features</b>	<b>4</b>
<b>Ordering Information</b>	<b>5</b>
<b>SENTRY Specifications</b>	<b>6</b>
Power and Control	6
Cellular	8
GNSS	10
SIM Card Reader	11
RS232 Serial Port	12
USB Port	14
Environmental	15
Mechanical	15
Dimensions	16
<b>SENTRY Images</b>	<b>17</b>
<b>SENTRY Interfaces</b>	<b>18</b>
RJ12 Power Connector	18
LED Indicators	19
USB Interface	21
RS232 Interface	21
GNSS Antenna Interface	22
Cellular Antenna Interface	23
SIM Card Interface	24
Reset Switch	25
<b>Getting started</b>	<b>26</b>
Overview	26

<b>Conformity Assessment</b>	<b>30</b>
<b>Copyright Information</b>	<b>32</b>
Copyright Declarations	32
Trademarks	32
<b>Disclaimer</b>	<b>33</b>
<b>About Siretta</b>	<b>34</b>



## Introduction

SENTRY is a stand-alone cellular network analyser that passively observes the cellular environment that it is placed in and sends the observed data back to a cloud-based management portal (CloudSURVEY) where this can be viewed and analysed. As well as passively observing the cellular environment, the SENTRY may optionally execute performance tests on the cellular network to which it is registered to measure such parameters as connection time, latency, and data transfer rates.

The SENTRY uses an embedded STM32F405 Arm® Cortex® M4 core processor combined with a cellular modem to perform the measurements and tests that the user demands on the cellular environment. Additionally, a GNSS receiver identifies the location at which each cellular survey is conducted. After performing the network tests, the SENTRY then automatically uploads the test results and positional data to the CloudSURVEY Portal using an encrypted link. Cellular network test results may then be reviewed on the CloudSURVEY portal.

CloudSURVEY (<https://www.cloud-survey.co.uk>) is the user interface to SENTRY after first time use configuration using the SirettaSPARK PC based device management tool. It is from CloudSURVEY that cellular surveys are started, stopped, paused and configured. Cellular surveys may be programmed to run continuously, or at set intervals, with optional overall surveying time limits. Survey results are presented both textually so that the detail may be seen, and graphically so that there is an overall view of what is happening.

All surveys will at least identify all the cells found, the network operator, signal strength, frequency of operation and the location of the discovered cells overlaid on a map.

Performance monitoring surveys additionally show cellular, TCP/IP and Socket registration times, uplink/downlink speeds, ping times, and comparative data with other cells of the same network.

In areas where there is poor and/or intermittent cellular coverage, it is possible to configure the SENTRY to output its measurements on an RS232 serial port rather than post data to the CloudSURVEY portal.



## Features

- » Works with 4G/LTE and 3G/UMTS networks. EU model additionally supports 2G/GSM networks. Bands covered vary by model.
- » Reports details of all cells visible to SENTRY:
  - » Operator
  - » Band/frequency
  - » Cell ID
  - » Signal strength
  - » LAC/TAC
  - » RSRP/RSRQ (LTE networks)
- » Reports network performance information of registered network:
  - » Cellular, TCP/IP & socket connection times
  - » Uplink/downlink performance
  - » Ping time
  - » Performance relative to other cells of the network operator
- » Simple management and control via the CloudSURVEY portal
- » Automatic repeated surveys at programmable intervals to see how coverage at a site varies over time.
- » Embedded GNSS receiver (supporting GPS/GLONASS/BeiDou/Galileo & QZSS) geolocates the position in which surveys are undertaken.
- » Serial port for local logging of survey data.
- » Cloud based updates of SENTRY software.
- » Fully integrates with SirettaSPARK device management tool.



## Ordering Information

The SENTRY is available in two versions. One intended for European network surveying, and the other for North America. They are sold as kits with all the accessories (power supply, antennas, etc) required for operation. All that the customer needs to supply is a SIM card.

Description	Order Code	Intended geographical region
SENTRY-G-LTE4 (EU) with accessories	61959	For European networks
SENTRY-G-LTE4 (USA) with accessories	61968	For North American networks

## Spare Accessories

Description	Order Code	Notes
DELTA26/X/SMAM/S/S/19	60537	Cellular antenna
MIKE18/3M/SMAM/S/S/26	62002	GPS antenna
CABLE: RS232 to USB 1.5M CABLE	29891	RS232 to USB adapter
CABLE: USB-A TO USB MINI B 1.0M LONG	60473	USB cable
PSU MULTI ADAPTOR WITH RJ12	61218	Universal input power supply

# SENTRY Specifications

## Power and Control

Power and control signals are applied through a latching RJ12 connector.

Figure 1: RJ12 Connector

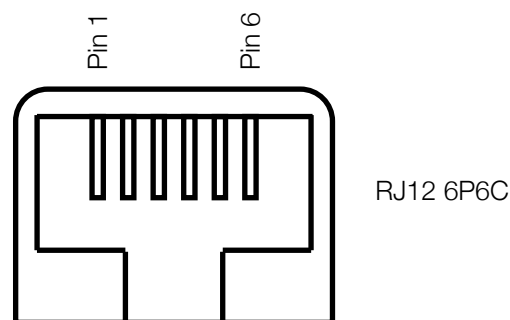

Table 1: Pin descriptions

Pin	Name	Description
1	V_IN	Input power (7 V to 42 V; 12 V @ 1 A recommended)
2	GPI_1	No Connect
3	NC	No Connect
4	NC	No Connect
5	GPI_2	No Connect
6	GND	Ground

Table 2: Signal input pin parameters (GPI1, SURVEY)

Pin	Conditions	Min	Typ	Max	Units
Maximum input voltage				42	Volts
Input threshold low				0.25	Volts
Input threshold high		1.75			Volts
Input resistance	+25°C	23.5		47	kΩ

All characteristics are over the operating temperature range of -40 to +85°C unless stated otherwise.

GPI\_1 and GPI\_2 input pins have an internal 47K Ohm pull down to ground, so it is acceptable to leave them disconnected if unused. This is their inactive state.



## Power Consumption

Table 3: Power Consumption by survey mode

State	Power Consumption (mA)
2G/GSM posted network survey, 5 minute cycle time	40 mA
3G/UMTS posted network survey, 5 minute cycle time	39 mA
4G/LTE posted network survey, 5 minute cycle time	37 mA
2G/GSM posted network, 5 minute cycle time	40 mA
3G/UMTS posted network, 5 minute cycle time	42 mA
4G/LTE posted network, 5 minute cycle time	52 mA
Surveying paused, 5 minute cycle time	35 mA

All power consumption figures are with the SENTRY powered from a 12 V power source and 25°C ambient temperature. Current measurements are average values measured over at least 15 minutes after the SENTRY has registered onto the cellular network, established a data connection to the CloudSURVEY portal and obtained the first GNSS position.

**Note:** These are average power measurements. Peak power occurs when the SENTRY is registering and transmitting to the cellular network and is considerably greater than the average values provided. It is highly recommended to use a power supply capable of supplying 1 A to power the SENTRY to prevent registration problems and the SENTRY from randomly disconnecting from the cellular network.

**Note:** The achieved power consumption depends on many things including received signal strength and the size of the survey data files uploaded to CloudSURVEY.



## Cellular

### Antenna Jack

SMA Jack (for use with a cellular antenna with SMA male connector)

Table 4: SMA connector characteristics

Parameter	Value
Impedance	50 $\Omega$
Mating torque	0.8 to 1.1 N-m

### Frequency bands supported

The frequency bands supported depend on the SENTRY model purchased:

Table 5: GSM / 2G Network support

Band	SENTRY-G-LTE4 (EU)	SENTRY-G-LTE4 (US)
B3 – 1800 MHz (DCS)	✓	✗
B8 – 900 MHz (Extended GSM)	✓	✗

Table 6: UMTS / 3G network support

Band	SENTRY-G-LTE4 (EU)	SENTRY-G-LTE4 (US)
B1 – 2100 MHz (IMT)	✓	✗
B2 – 1900 MHz (PCS)	✗	✓
B3 – 1800 MHz (DCS)	✓	✗
B4 – 1700 MHz (AWS-1)	✗	✓
B5 – 850 MHz (Cellular)	✗	✓
B8 – 900 MHz (Extended GSM)	✓	✗



Table 7: LTE / 4G network support

Band	SENTRY-G-LTE4 (EU)	SENTRY-G-LTE4 (US)
B1 – 2100 MHz (IMT)	✓	✗
B2 – 1900 MHz (PCS)	✗	✓
B3 – 1800 MHz (DCS)	✓	✗
B4 – 1700 MHz (AWS-1)	✗	✓
B5 – 850 MHz (Cellular)	✗	✓
B7 – 2600 MHz (IMT-E)	✓	✗
B8 – 900 MHz (Extended GSM)	✓	✗
B12 – 700 MHz (Lower SMH)	✗	✓
B13 – 700 MHz (Upper SMH)	✗	✓
B14 – 700 MHz (Upper SMH)	✗	✓
B20 – 800 MHz (Digital Dividend)	✓	✗
B28A* – 700 MHz (APT)	✓	✗
B66 – 1700 MHz (Extended AWS)	✗	✓
B71 – 600 MHz (Digital Dividend)	✗	✓

\* B28A is a subset of B28 using the lower duplexer frequencies (Tx : 703-733 MHz / Rx : 758-788 MHz)

## Required cellular antenna characteristics

A cellular antenna is required that supports the frequency bands supported by the SENTRY (see previous table) in addition to having the following characteristics:

Table 8: Cellular antenna characteristics

Parameter	Value
Gain	< 3 dBi
Impedance	50 $\Omega$
Input power	> 24 dBm Average power
VSWR absolute max	$\leq$ 10:1 (limit to avoid permanent damage)
VSWR recommended	$\leq$ 2:1 (limit to fulfil all regulatory requirements)



## GNSS

### Antenna Jack

SMA Jack (for use with an active GNSS antenna with SMA male connector)

Table 9: SMA connector characteristics

Parameter	Value
Impedance	50 $\Omega$
Mating torque	0.8 to 1.1 N-m

### Frequency bands / constellations supported

Table 10: Supported frequency bands & constellations

Constellations	Frequency	Band
GPS	1575.42 MHz	L1
GLONASS	1602 MHz	L1OF
Galileo	1575.42 MHz	E1
BeiDou	1575.42 MHz	B1C
QZSS	1575.42 MHz	L1

### Characteristics

Table 11: GNSS characteristics

Parameters		Typical Measurement	Notes
Sensitivity	Standalone or MS (Mean Shift) based tracking	-160 dBm	
	Acquisition	-147 dBm	
	Cold Start	-145 dBm	
TTFF	Hot	1.1 s	GPS & GLONASS Simulator test
	Warm	22.1 s	GPS & GLONASS Simulator test
	Cold	29.94 s	GPS & GLONASS Simulator test
Accuracy		< 2.0 m	GPS & GLONASS Simulator test @CEP50

Characteristics assume that an antenna meeting the required GNSS antenna characteristics is used and has a site of the sky. Meeting the recommended gain specification is especially important.



### Required GNSS antenna characteristics

A GNSS antenna is required that supports a frequency supported by the SENTRY (see table 12). 1575.42 MHz is recommended as using this frequency will provide the navigation system with visibility to the most satellites. In addition, the GNSS antenna should have the following characteristics:

Table 12: GNSS antenna characteristics

Parameter	Value
Antenna type	Active
Impedance	50 $\Omega$
Gain	14 to 17 dB recommended
Polarity	RHCP

### SIM Card reader

SIM card reader for mini-SIM (2FF) meeting ISO/IEC 7810:2019, ID-000 (25 mm x 15 mm)

Table 13: SIM card reader characteristics

Parameter	Value
SIM card reader type	Push-Push type with card detection switch
SIM card voltage support	1.8 V and 3 V
Durability	10,000 cycles
Insertion force	7 N Maximum

## RS232 Serial port

9-Way RS232 connector compliant with TIA-232-F with all signals electrically connected. The SENTRY is a DCE device (Data terminating).

Figure 2: RS232 port pin numbering

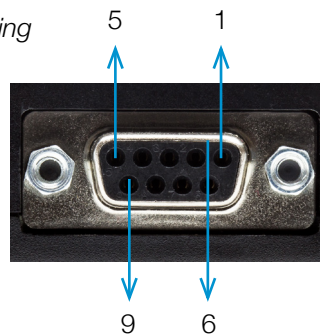

Table 14: RS232 port pin descriptions

Pin	Name	Usage	Direction
1	DCD	Data Carrier Detect – DCE is receiving data from remote DCE	OUT
2	RXD	Received Data – data from DCE to DTE	OUT
3	TXD	Transmitted Data – data from DTE to DCE	IN
4	DTR	Data Terminal Ready – DTE is ready to operate	IN
5	GND	Ground	-
6	DSR	Data Set Ready – DCE is ready to operate	OUT
7	RTS	Request to Send - hardware flow control, DTE requests to send	IN
8	CTS	Clear to Send - hardware flow control, DCE is ready to receive	OUT
9	RI	Ring Indicator - indicates the incoming calls	OUT



Table 15: RS232 transmitter electrical characteristics

Transmitter Parameter	Conditions	Min	Typ	Max	Units
Output Voltage Swing	3k $\Omega$ load to ground	$\pm 5.0$	$\pm 5.4$		Volts
Output short circuit current			$\pm 35$	$\pm 60$	mA

Table 16: RS232 receiver electrical characteristics

Receiver Parameter	Conditions	Min	Typ	Max	Units
Voltage Range		-25		25	Volts
Threshold Low		0.6	1.2		Volts
Threshold High			1.8	2.4	Volts
Hysteresis			0.3		Volts
Resistance	+25 °C	3	5	7	k $\Omega$

All characteristics are over the operating temperature range of -40 to +85 °C unless stated otherwise.

## USB Port

Figure 3: USB port illustration

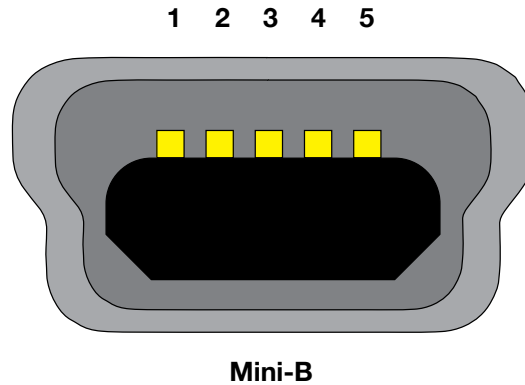

Table 17: USB characteristics

Parameter	Value
Connector	Mini-B
USB Version	2.0 high-speed (480 Mbps) interoperable with full speed (12 Mbps)
Power consumption	1 mA maximum taken from VBUS

Table 18: USB electrical characteristics

Pin	Name	Description	Direction	Minimum	Nominal	Maximum
1	VBUS	USB Power (when applied)	IN	4.75 V	5 V	5.25 V
2	D-	Differential data negative	IN/OUT	-0.5 V	3.3 V	3.6 V
3	D+	Differential data positive	IN/OUT	-0.5 V	3.3 V	3.6 V
4	-	-	IN	-	-	-
5	GND	Ground	IN / OUT	-	0 V	-



## Environmental

Table 19: Environmental parameters

Parameter	Value
Operating Temperature	-40 to +85 °C
Storage Temperature	-40 to +85 °C
Humidity Range	20 to 85% RH non-condensing

## Mechanical

Table 20: Mechanical parameters

Parameter	Value
Dimensions	93 mm x 67 mm x 28 mm (excluding protruding connectors)
Weight	100 g (excluding antennas, SIM card and packaging)
IP Rating	30

See Dimensions section for detailed drawings (next page).

## Dimensions

Figure 4: Side view showing LEDs and SIM card holder slot

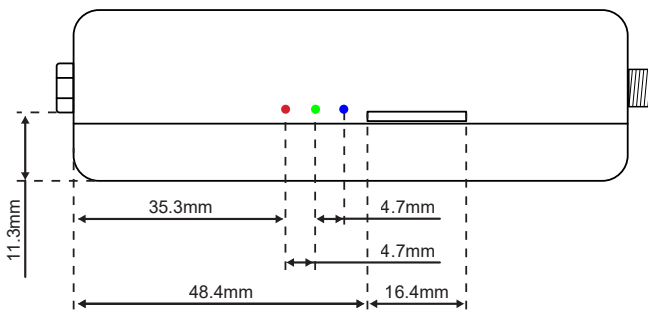

Figure 5: End view showing RS232 and USB connectors

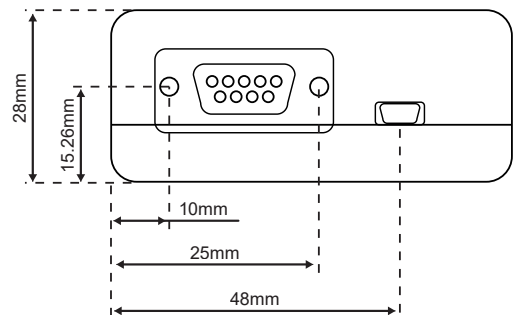

Figure 6: Back view showing RS232, USB connectors and Reset switch

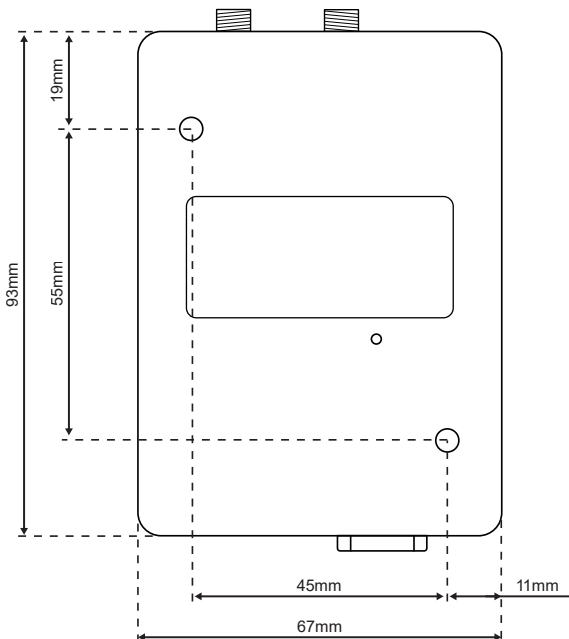
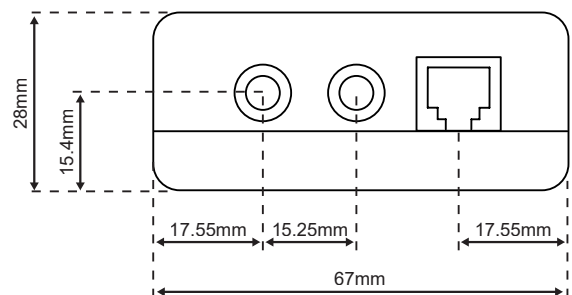

Figure 7: End view showing RS232 and USB connectors





## SENTRY Images

Figure 8: Front view of the SENTRY



Figure 9: 3D-view of the SENTRY



Figure 10: Bottom view of the SENTRY



Figure 11: Top view of the SENTRY



## SENTRY Interfaces

### RJ12 Power Connector

This connector is primarily used for applying DC power to the SENTRY. It also has some control signals that may be left disconnected if not used. Connect the supplied power adapter to this interface.

Figure 12: RJ12 power connector on SENTRY

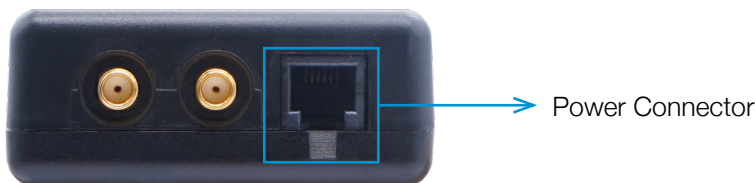

Table 21: RJ12 connector pin descriptions

Pin	Name	Description
1	V_IN	Input power (7 V to 42 V; 12 V @ 1 A recommended)
2	GPI_1	No Connect
3	NC	No Connect
4	NC	No Connect
5	GPI_2	No Connect
6	GND	Ground

#### V\_IN

When connecting and registering with the network, power consumption will be at a maximum and the changes in current can be rapid. This can cause problems for some power supplies which may not be able respond quickly to the changes in current. For this reason, Siretta recommends using a 12 V, 1 A power supply so that any voltage drops due to poor regulation will not affect the SENTRY operation.

#### GPI\_1

Currently unused input function. Leave no connect.

#### NC

No connection

#### GPI\_2

Currently unused input function. Leave no connect.

#### GND

Ground reference for input power and input pins



## LED Indicators

The SENTRY has three LEDs (Red, Green, Blue) on the side of the unit next to the SIM card slot. LED indication is invalid for the first 15 seconds after power-up while the SENTRY initialises itself.

Figure 13: Led indicators on SENTRY

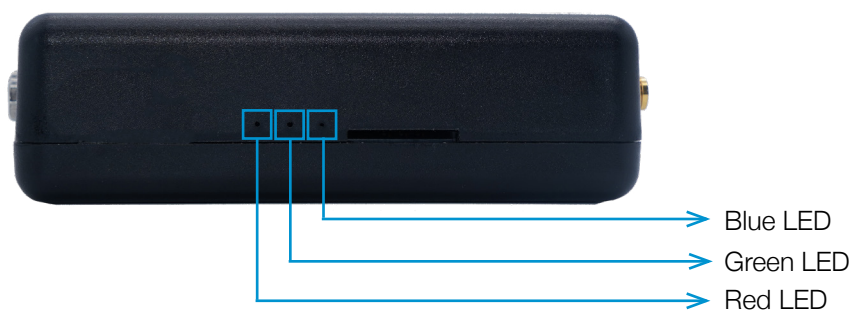

The three LEDs indicate the operating state of the SENTRY:

- » The Red LED indicates the connection state to the cellular network (normally slow blink).
- » The Green LED indicates the IP network state connection state (normally on).
- » The Blue LED indicates the embedded application state (normally on, or flashing at 4 Hz).



Table 22: LED state indication

LED	State	Explanation
Red	Solid On	Not registered to cellular network
	Flash (1 sec on, 2 seconds off)	Registered to cellular network
Green	Flash (8 Hz)	SIM error
	Flash (5 Hz)	Modem starting
	Flash (4 Hz)	Modem on
	Flash (3 Hz)	Unregistered to cellular network
	Flash (2 Hz)	Registered to cellular network
	Flash (1 Hz)	Network initialising
	Solid on	Network enabled
	Off	Network disabled
Blue	Flash (8 Hz)	Obtaining current time
	Flash (4 Hz)	Surveying
	Flash (3 Hz)	Data transfer to/from CloudSURVEY
	Flash (2 Hz)	Debug / reset state
	Solid On	On / ready
	Off	Restarting

All three LEDs flashing in synchronisation at 1 Hz means that the APN/username/password settings are wrong, or that no SIM has been inserted.

## USB Interfaces

The USB interface is used to connect the SENTRY to a PC. It is only required to use the USB cable when configuring the SENTRY for the first time, or if changing the SIM and new SIM settings are required for the SENTRY. The SENTRY cannot be powered by the USB interface.

Figure 14: USB Interface on SENTRY



Use the SirettaSPARK tool to configure the SENTRY once it has been connected by USB to a PC (see [Getting Started](#) section).

The USB interface is not designed to and is unable to power the SENTRY.

## RS232 Interfaces

The RS232 interface is provided to send survey data out to a local datalogger where connectivity to the CloudSURVEY portal may be intermittent.

Figure 15: RS232 port on SENTRY



Because the use case of the RS232 interface is mainly for areas of poor reception, it is suggested that the SENTRY to set up to start a new survey with each powerup before it is placed in the survey location. Remember, the SENTRY must be online to receive this instruction before it is moved to the survey location. The CloudSURVEY portal will indicate when the SENTRY has received the survey command and is ready to be moved. Refer to the CloudSURVEY User Manual for information on how to configure and execute surveys.

## GNSS Antenna Interface

Attach a GNSS antenna to the GNSS antenna interface by screwing it onto the SMA connector. Not connecting a GNSS antenna will not prevent the SENTRY from surveying. In this case, no position information will be captured with a survey and surveys will take longer because of the attempts by the SENTRY to establish its position.

Figure 16: GNSS antenna connector on SENTRY

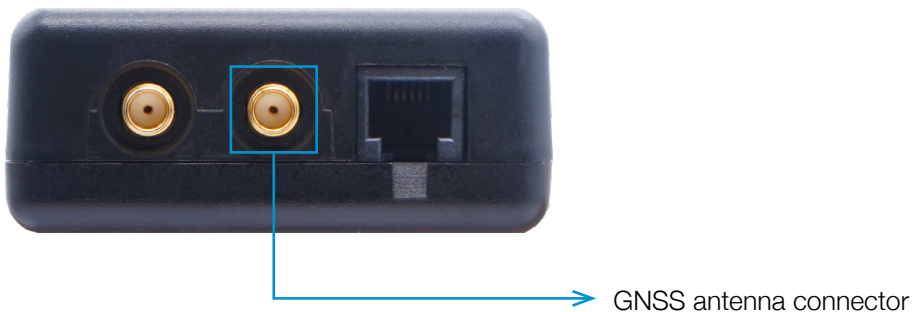

Ideally, the antenna should be placed in a location where there is good visibility of the sky as the accuracy will improve with the number of satellites visible. However, the receiver is still capable of getting an approximate position indoors if placed close to a window.

When first powered, the SENTRY will try for up to 2 minutes to get a position before informing the CloudSURVEY portal that it is online and ready to survey.

When surveying, the SENTRY will try for up to 90 seconds to obtain a position before starting a survey. Should a position not be obtained, the last known position will be used.



## Cellular Antenna Interface

Attach a cellular antenna to the cellular antenna interface by screwing it onto the SMA connector. This can either be the antenna supplied with the accessory kit, or it can be a customer supplied antenna.

Figure 17: Cellular antenna connector on SENTRY

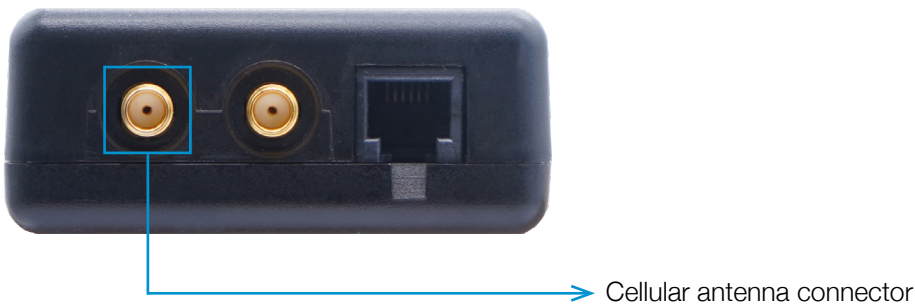

If surveying in preparation to installing some cellular equipment, it is recommended that the antenna being proposed for the installation be used with the SENTRY so that the survey results obtained will account for the characteristics of the antenna.

The Siretta supplied antenna has a swivel joint which allows it to be placed in any orientation. Moving the antenna so that it is pointing directly upwards is likely to give the best cellular reception, especially in poor reception areas.

## SIM Card Interface

To be able to use the SENTRY, it is required that the user supply their own SIM card to provide the Internet connectivity to CloudSURVEY required to operate the SENTRY. The following is the SIM requirement for network surveying:

- » Form factor: mini-SIM (2FF) (25 mm x 15 mm).
- » Data enabled.
- » Supports SMS/IMS (optional but recommended to improve performance).
- » Consider using a roaming SIM (that can connect to any network) when surveying in poor coverage areas.

For performance monitoring these additional points should be considered:

- » Needs to support the network(s) to be tested.
- » Adequate data allowance.

Insert the SIM to be used with the SENTRY as shown:

Figure 18: SIM card interface on SENTRY



While it is possible to use any data enabled SIM card with the SENTRY, in practice some SIM cards are much easier to use than others. Generally, a contract SIM is preferable as these are typically already activated when provided so there is no user interaction required to prepare them for use.

Pay As You Go (PAYG) SIMs are usually more complicated as they require activation before use, and the activation process may involve receiving one or more SIM messages and sometimes calling a number. In some cases, it is required to install and run a mobile app to activate the SIM. All extremely easy on a phone, but not possible with the SENTRY. So, in this case the SIM will need to be activated in a phone, and then transferred to the SENTRY when activated.

There are many network operators, and they all behave differently when a PAYG SIM runs out of credit. Generally, it is not wise to allow a deployed SENTRY run out of credit as usually it is required to restart the SENTRY once the credit has been added. For that reason, a contract SIM is recommended, or a PAYG SIM with automatic top-up enabled.



## Reset Switch

A reset on the bottom of the SENTRY may be used to reset the SENTRY to factory default settings.

Figure 19: Reset switch on SENTRY

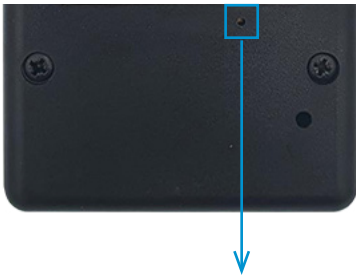

Use the included pin reset tool or a paperclip to press the recessed switch while applying power to the SENTRY. Keep the switch pressed for 10 seconds after applying power and then release it. This will return the SENTRY to factory default settings, which means that the saved APN/Username/Password will be deleted. It does not remove the SENTRY's association with a CloudSURVEY account, nor the surveys stored on the CloudSURVEY account.



## Getting Started

This section explains how to prepare the SENTRY for first use and connection to the CloudSURVEY Portal.

### Overview

The steps involved to prepare for the first survey are:

1. Select and procure a SIM card.
2. Insert SIM can into the SENTRY.
3. Connect Cellular and GNSS antennas.
4. Connect power supply and turn SENTRY on.
5. Connect SENTRY to a Windows PC using the USB cable.
6. Register an account on the Siretta Portal.
7. Configure SENTRY using the SirettaSPARK tool.
8. Use CloudSURVEY portal to initiate surveys and view results.

### Select and procure a SIM card

Please read SIM Card Interface section for details of SIM card requirements and selection. The user is required to provide their own SIM card in order to be able to use the SENTRY.

### Insert SIM can into the SENTRY

Please read SIM Card Interface section for details of how to correctly insert the SIM card.

### Connect Cellular and GNSS antennas

Please read the GNSS antenna Interface and Cellular Antenna Interface sections to identify the GNSS and Cellular antenna connectors and connect antennas to them. A suitable GNSS and cellular antennas are supplied as part of the accessory kit, but other antennas may be used with SENTRY. See [Cellular](#) and [GNSS](#) sections for the details of the antenna requirements.

### Connect power supply and turn SENTRY on

Connect the power supply supplied with the accessory kit to the RJ12 Power Connector. The supplied power supply has only power and ground connected. If control of surveys with the SURVEY pin on the RJ12 connector is required, then the user is required to implement this external circuit themselves. Siretta offers a 1 m cable with the RJ12 connector connected as part number 61064 which is available separately.



### Connect SENTRY to a Windows PC using the USB cable

Once powered, use the USB cable supplied with the accessory kit to connect the SENTRY to the PC that will be used to initially configure the SENTRY. There are no USB drivers that require installation. The SENTRY will appear as a 'USB Serial Device' under 'Ports (COM & LPT)' of Windows Device Manager.

### Register an account on the Siretta Portal

Siretta uses a unified login procedure to access some areas of Siretta's websites:

<https://www.siretta.com/>

<https://www.siretta-link.com/>

<https://www.cloud-survey.co.uk/>

An account created for one of these websites will also work on the other websites. Account logins are a combination of the users email address as a username and a password.

Use a web browser to connect to <https://portal.siretta.com>. Either log in with existing credentials if they exist, otherwise create an account and log into the Siretta Portal.

### Configure SENTRY using the SirettaSPARK tool

Once logged onto the Siretta portal, navigate to Logistics > SirettaSPARK tool or navigate there directly using this link: [https://portal.siretta.com/portal\\_siretta\\_spark.php](https://portal.siretta.com/portal_siretta_spark.php).

Download and run the SirettaSPARK application. The SirettaSPARK user is required to register SirettaSPARK to the Siretta account that they created. Please refer to the SirettaSPARK User's manual for details of how to use SirettaSPARK.

When SirettaSPARK is attached to a SENTRY and the configuration window opened to configure a new un-allocated SENTRY, a pop-up box opens suggesting that the SENTRY be allocated to the user's account:

Figure 20: Notice of device allocation

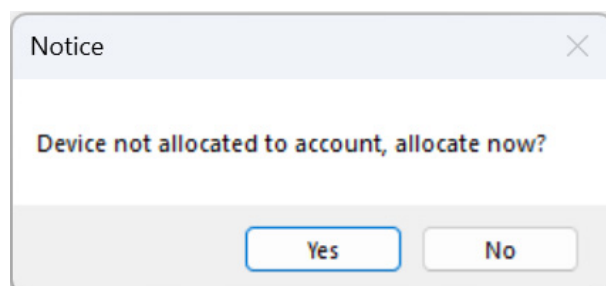

Clicking 'Yes', the SirettaSPARK application associates the serial number of the SENTRY being configured to the users account so that the SENTRY will automatically appear on the users CloudSURVEY account.



As explained in the SirettaSPARK User's Manual go to the SENTRY configuration settings and enter the APN and any username/password/PIN required by the SIM card provider and save the configuration to the SENTRY.

Figure 21: SirettaSPARK configuration

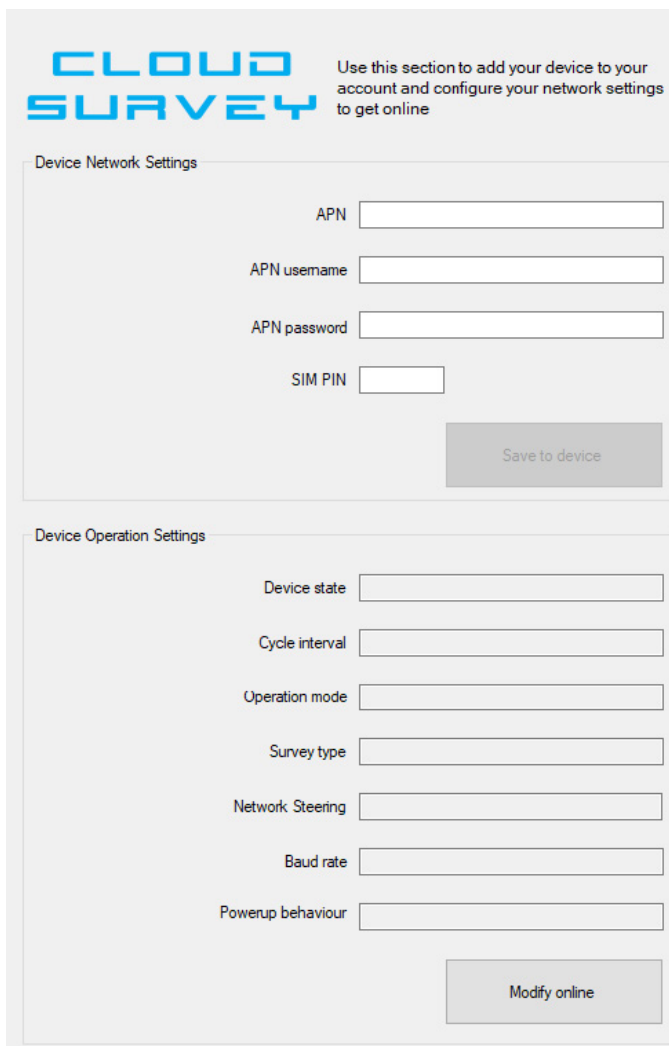

**CLOUD SURVEY** Use this section to add your device to your account and configure your network settings to get online

**Device Network Settings**

APN

APN username

APN password

SIM PIN

Save to device

**Device Operation Settings**

Device state

Cycle interval

Operation mode

Survey type

Network Steering

Baud rate

Powerup behaviour

Modify online

With network settings now configured in the SENTRY, turn off/remove the power and unplug the USB cable. Then re-apply power. The SENTRY will then connect to the cellular network. On first boot after the SIM settings have been applied, this will take several minutes. When the green and blue LEDs are continuously lit, and the red LED is blinking slowly, the SENTRY is online and ready for use.



### Use CloudSURVEY portal to initiate surveys and view results

Log into CloudSURVEY using the same log in credentials used for <https://portal.siretta.com>. The SENTRY that has just been configured will be visible in the device list. Each SENTRY that is added may be identified by the six-digit number displayed in the device ID which is the last 6 digits of the serial number printed on the product label.

Figure 22: CloudSURVEY interface

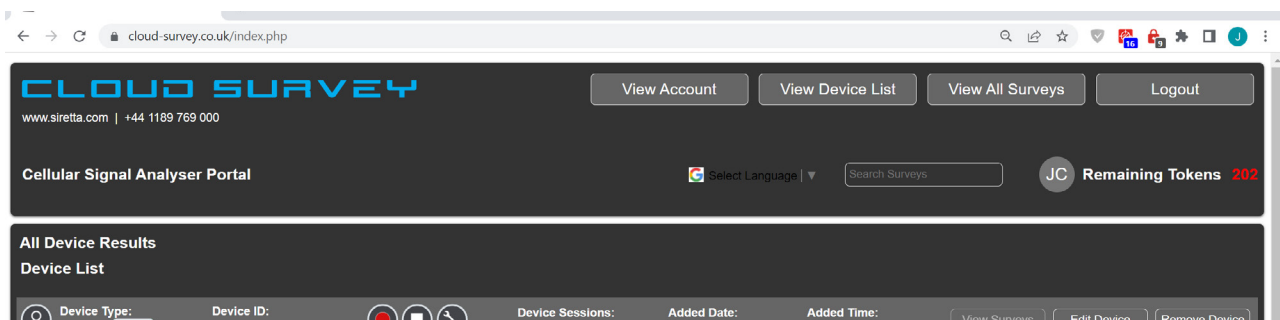

Please now refer to the CloudSURVEY User's Manual for details of how to use CloudSURVEY to conduct and view surveys.



## Conformity Assessment



Device ID 2AVL4-SENTRY-G-LTE

This device complies with part 15 of the FCC Rules. Operation is subject to the following two conditions: (1) This device may not cause harmful interference, and (2) this device must accept any interference received, including interference that may cause undesired operation.

Any Changes or modifications not expressly approved by the party responsible for compliance could void the user's authority to operate the equipment.

Note: This equipment has been tested and found to comply with the limits for a Class B digital device, pursuant to part 15 of the FCC Rules. These limits are designed to provide reasonable protection against harmful interference in a residential installation. This equipment generates uses and can radiate radio frequency energy and, if not installed and used in accordance with the instructions, may cause harmful interference to radio communications. However, there is no guarantee that interference will not occur in a particular installation. If this equipment does cause harmful interference to radio or television reception, which can be determined by turning the equipment off and on, the user is encouraged to try to correct the interference by one or more of the following measures:

- » Reorient or relocate the receiving antenna.
- » Increase the separation between the equipment and receiver.
- » Connect the equipment into an outlet on a circuit different from that to which the receiver is connected.

Consult the dealer or an experienced radio/TV technician for help.

This equipment complies with FCC radiation exposure limits set forth for an uncontrolled environment. This equipment should be installed and operated with minimum distance 20 cm between the radiator and your body.



Device ID 28712-SENTRY-G-LTE

This device contains licence-exempt transmitter(s)/receiver(s) that comply with Innovation, Science and Economic Development Canada's licence-exempt RSS(s). Operation is subject to the following two conditions:

1. This device may not cause interference.
2. This device must accept any interference, including interference that may cause undesired operation of the device.

L'émetteur/récepteur exempt de licence contenu dans le présent appareil est conforme aux CNR d'Innovation, Sciences et Développement économique Canada applicables aux appareils radio exempts de licence. L'exploitation est autorisée aux deux conditions suivantes :

1. L'appareil ne doit pas produire de brouillage;
2. L'appareil doit accepter tout brouillage radioélectrique subi, même si le brouillage est susceptible d'en compromettre le fonctionnement.

This equipment should be installed and operated with a minimum distance of 20 centimeters between the radiator and your body.

Cet équipement devrait être installé et actionné avec une distance minimum de 20 centimètres entre le radiateur et votre corps.



## Copyright Information

### Copyright Declarations

© 2023 Siretta Ltd, all rights reserved

No part of this publication may be reproduced, transmitted, transcribed, stored in a retrieval system, or translated into any language without the written permission of Siretta Ltd.

### Trademarks

Windows and Microsoft are registered trademarks of Microsoft Corporation.

Siretta Ltd is an independent business and is neither affiliated with, nor authorized, sponsored, or approved by, Microsoft Corporation.

Arm and Cortex are registered trademarks of Arm Limited (or its subsidiaries) in the United States and/or elsewhere.

All other trademarks are the property of their respective owners.



## Disclaimer

The information contained in this document is proprietary to Siretta. Siretta has made every effort to ensure that the accuracy of the information contained within this document is accurate. Siretta does not make any warranty as to the information contained within this document and does not accept any liability for any injury, loss or damage of any kind incurred by the use of this information.

Siretta does not take responsibility for any application developed using the modem characterized in this document and notes that any application of this modem must comply with the safety standards of the applicable country and comply with the relevant wiring rules. Siretta reserves the right to make modifications, additions and deletions to this document due to typographical errors, inaccurate information, or improvements to equipment at any time and without notice. Such changes will be incorporated into new editions of this document.

All rights reserved.

Please refer to the [Siretta Ltd](https://www.siretta.com) website for the latest version of this document.

© 2023 Siretta Ltd



## About Siretta

Siretta is a wireless communications company located in Reading, United Kingdom manufacturing & supplying industrial IoT products since 1998.

Siretta's product portfolio is made up of:

- » Antennas, plus their associated Cable Assemblies & Adapters,
- » Cellular Network Analysers
- » Industrial Modems
- » Industrial Routers
- » Associated Cloud Management

Siretta supplies products directly and via a worldwide network of distributors, into numerous markets and applications across the globe.

Siretta's distribution partners range from industrial IoT specialists through to global catalogue organisations.

Whether "off the shelf" or custom solutions are required, Siretta has a wide portfolio of products to fit many types of application.

Siretta's extensive knowledge and experience in the wireless market allows support of a wide range of customer applications, focusing on frequencies between 400 MHz to 6 GHz. These encompass modems, routers and antennas for:

- » Cellular technologies: GSM / UMTS / LTE (including Cat M & NB) / 5G NR and other cellular technologies as they emerge.
- » Global positioning: GPS/GNSS
- » WLAN/Wi-Fi

Whilst providing the above products for the industrial cellular market, Siretta also has a number of antennas to cover applications for:

- » Bluetooth, Zigbee, ISM band, LoRa and Sigfox

With a heavy emphasis on design, Siretta has a team of dedicated Engineers and Product Managers, who specialise in wireless applications.

Siretta continually makes significant investment in R&D endeavouring to provide customers with market leading, future-proofed, wireless solutions. Siretta works closely with many technology partners to stay at the forefront of industrial IOT.



Enabling Industrial IoT

**sales** +44 (0)118 976 9000

**email** sales@siretta.com

**www.siretta.com**

Siretta Ltd  
Basingstoke Road  
Spencers Wood  
Reading  
Berkshire  
RG7 1PW  
United Kingdom

Company No. 08405712  
VAT Registration No. GB163 04 0349

